

**TANCO AUTOWRAP
1080ATP MODEL 1999
C/W "TWIN-PAK" LOADING ARM
OPERATORS HANDBOOK
AND
PARTS LIST
WD90-1080-ATP-MO199**

GUARANTEE

Subject as hereunder provided, the Sellers undertake to correct either by repair or at their election by replacement any defect of material or workmanship which occurs in any of its goods within twelve months after delivery of such goods to first user, with the exception of contractors or commercial users when warranty period is six months.

In respect of Autowraps the warranty period is for 12 months or 8000 bales, whichever occurs first.

In respect of Aerways, tine breakage will be assessed on an individual basis in every case.

The term goods when used in this document means the article or articles described in Invoice as sold by the Sellers but does not include equipment or proprietary parts or accessories not manufactured by the Sellers. The Sellers, however, undertake to pass on so far as they legally can to the first user the benefit of any warranty given to the Sellers by the suppliers of such equipment, parts or accessories.

This understanding shall not apply to:-

- (a) Any goods which have been sold by the first user.
- (b) Any goods which have been injured by unfair wear and tear, neglect or improper use.
- (c) Any goods the identification marks of which have been altered or removed.
- (d) Any goods which have not received the basic normal maintenance such as tightening of bolts, nuts, tines, hose connections and fittings and normal lubrication with the recommended lubricant.
- (e) The use of any product on tractors exceeding the recommended horsepower.
- (f) Any goods which have been altered or repaired other than on instruction or with the written approval of the Seller or to which any part not manufactured or having written approval by the Sellers have been fixed.
- (g) Any second-hand goods or part thereof.

Any allegedly defective part or parts returned to the Sellers must be sent carriage paid. No claim for repair or replacement will be entertained unless upon discovery of the alleged defect written notification is sent to the Sellers giving, at the same time, the name of the Buyer from whom the goods were purchased and the date of purchase, together with full details of the alleged defect and the circumstances involved, also the serial number of the machine etc.

The Sellers shall be under no liability to their Buyers and first or subsequent users of their goods or to any other person or persons for loss or damages howsoever arising in respect of either personal injuries or for arising out of, or in any way connected with or arising from the manufacturers sale, handling, repair, maintenance, replacement or use of its goods or the failure or malfunction of any of its goods.

Representation and/or warranties made by any person (including Buyers and employees and other representatives of the Seller) which are inconsistent or conflicting with these conditions are not binding upon the Sellers unless given in writing and signed by a Director of the Sellers.

CLAIMS.

If you wish to make a claim under guarantee:

- 1: Immediately, stop using the machine.
- 2: List the details of the machine, its serial number and the part number of the damaged part.
- 3: Consult with your Tanco dealer (supplier) and have him forward your claim and the damaged item to Tanco.

EXTENDED WARRANTY

Applies only to Film Stretch Unit

SUBJECT TO THE FOLLOWING CONDITIONS:-

1. UPON PURCHASE OF THE TANCO BALE WRAPPING MACHINE, PLEASE COMPLETE AND RETURN THE ATTACHED FORM.
2. THE SERIAL NUMBER IS ON THE CENTRE ROD OF THE K.O. PRE-STRETCH FILM DISPENSER.
3. RETURN THE SLIP DIRECT TO K.O. PRESSURE FRAMES OR TANCO ENGINEERING WITHIN ONE MONTH OF PURCHASE.

UPON RECEIPT, K.O. PRESSURE FRAMES LIMITED WILL WARRANTY THE FILM TENSIONING UNIT FOR 2 YEARS FROM DATE OF PURCHASE SUBJECT TO THE TERMS AND CONDITIONS OF THE TANCO MACHINE WARRANTY AND SUBJECT TO THE CORRECT LUBRICATION OF THE FILM DISPENSERS GEARBOX, WHEREBY ONE SHOT OF GREASE EVERY 500 BALES. USE ONLY NLGA 0 GRADE LITHIUM GREASE, WE RECOMMEND SILKOLENE G46 SL EP GREASE OR APPROVED EQUIVALENT, i.e. ESSO BEACON EPO.

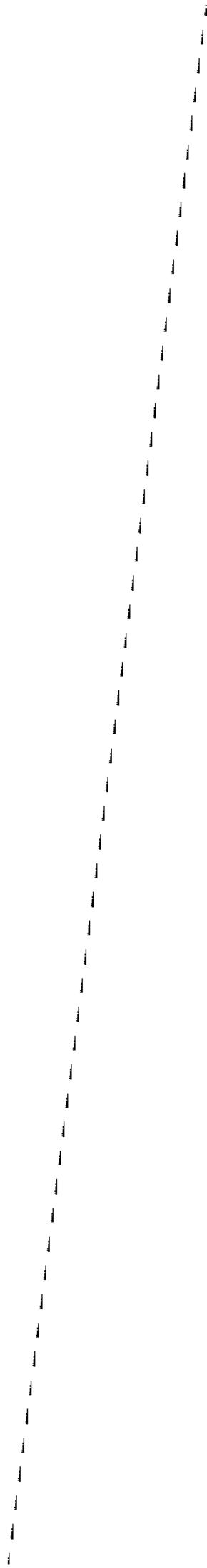

WARRANTY RETURN FORM

PURCHASERS

NAME:.....

ADDRESS:.....

POST CODE:..... **COUNTRY:**.....

TELEPHONE NO:.....

FAX NO:.....

K.O.P.F. DISPENSER SERIAL NUMBER(S):.....

TANCO AUTOWRAP SERIAL NUMBER(S):.....

DATE OF PURCHASE:.....

*PLEASE RETURN TO: K. O. PRESSURE FRAMES LTD,
UNIT 3, CHIDDINGSTONE, CAUSEWAYESTATE,
NR. PENSHURST, KENT TN11 8JU.
ENGLAND.*

OR *TANCO ENGINEERING CO. BAGENALSTOWN, CO. CARLOW,
EIRE.*

INDEX	1080ATP MODEL	PAGE NO.
GENERAL SAFETY INSTRUCTION		1 2 3
SAFETY INSTRUCTIONS		4
SAFETY DECALS		5
TECHNICAL SPECIFICATIONS		6
PRE DELIVERY INSTRUCTIONS		7 8 9
TRANSPORT INSTRUCTIONS		10
MACHINE IDENTIFICATION		10
PREPARATION OF NEW MACHINE		10
HYDRAULIC CONNECTIONS		10
JUNCTION BOX AND CONTROLLER		11
AUTOMATIC BALE WRAP CONTROLLER		12
OPERATOR ACCESSIBLE MONITOR PROGRAMMES		13 14 15
MODE OF OPERATION		16
OPERATING INSTRUCTIONS		17
WARNING: LIFT ARM		18
"TWIN PAK" LOADING ARM OPERATING INSTRUCTIONS		19
"TWIN PAK" LOADING SEQUENCE		20
FILM OVERLAP SYSTEM		21
SERVICE AND MAINTENANCE		22 23
FILM THREADING DIAGRAM		24
GEARBOX CHAIN DRIVE TENSIONING SYSTEM		25
TURNTABLE CHAIN DRIVE TENSIONING SYSTEM		26
BALE BELT TRACKING		27
BALE BELT TRACKING ILLUSTRATED		28
ELECTRICAL COMPONENTS 1080-ATP MODEL		29
HYDRAULIC CIRCUIT DIAGRAM 1080-ATP MODEL		30
HYDRAULIC COMPONENTS 1080-ATP MODEL		31
PARTS LIST FOR ABOVE		32
FITTING 2 WAY SOLENOID VALVE		33
CONSTANT INDEXING DRIVE ASSY		34
PARTS LIST FOR ABOVE		35
AUTOWRAP ILLUSTRATED		36
PARTS LIST FOR ABOVE		37
TURNTABLE CHAIN DRIVE ASSEMBLY		38
PARTS LIST FOR ABOVE		39
BALE BELT ROLLER MOUNTING BRACKETS		40
PARTS LIST FOR ABOVE		41
FILM DISPENSING SYSTEM 1080-ATP MODEL		42
PARTS LIST FOR ABOVE		43
VALVE/JUNCTION BOX/FILTER & DIVERTER VALVE MTG. BKT. ASSY		44
"TWIN-PAK" LIFT ARM ASSEMBLY		45
PARTS LIST FOR ABOVE		46
HYDRAULIC BALE RAMP		47
PARTS LIST FOR ABOVE		48
FAULT FINDING SUMMARY		49
HYDRAULIC CUT & START UNIT ILLUSTRATED		50
PARTS LIST FOR ABOVE		51
RECHARGING HYDRAULIC CYLINDER		52
TURNTABLE LOCKING ARRANGEMENT		53
SENSOR MAGNET MOUNTING BRACKETS		54
LIGHTING KIT		55

GENERAL SAFETY RECOMMENDATIONS

Before operating the machine, always ensure that the tractor and machine meet with work safety and road traffic regulations.

BASIC PRINCIPLES

- 1: In addition to the recommendations given in this manual, legislation on work safety and accident prevention must also be respected.
- 2: Advice is indicated on the machine, specifying safety recommendations in order to prevent accidents.
- 3: Before travelling on public roads, the operator must ensure that the machine conforms to road traffic regulations.
- 4: Before starting work, the operator must be familiar with all machine controls, handline devices and their functions. once at work, it is too late to do this!
- 5: Do not wear loose clothing which could become caught up in moving elements.
- 6: The tractor should be equipped with a safety cab.
- 7: Before starting up the machine and beginning work, check the surrounding area (beware of children!) , make sure there is sufficient visibility. Keep all people and animals away from the danger zone of the machine (risk of projection!).
- 8: Carrying people or animals on the machine when working or in transport is strictly forbidden.
- 9: Machine must only be attached to tractor using means provided and in accordance with current safety standards.
- 10: Special care should be taken when attaching or removing the machine from the tractor.
- 11: Before transporting the machine on public roads, ensure that all legally required guards and indicators (lights, reflectors ...) are in place and in good operation.
- 12: All operating controls (cords, cables, rods etc.) must be positioned so that they cannot be set off accidentally, risking accident or damage.
- 13: Before travelling on public roads, put the machine into its transport position as instructed in this operators manual.
- 14: Never leave the tractor seat while the machine is operating.
- 15: Drive speed must be adapted to ground conditions as well as to roads and paths. Always avoid abrupt changes of direction.
- 16: Before operating the machine, ensure that all safety guards are firmly in place and in good condition. If worn or damaged, replace immediately.
- 17: Before operating the machine, check the tightness of all nuts and bolts, particularly on fixing elements (blades, tines, knives, spades etc..)
- 18: Keep clear of the machine operating area.
- 19: **WARNING!** Danger of crushing and shearing can exist when components are operated by hydraulic or pneumatic controls.
- 20: Before leaving the tractor or before adjusting, maintaining or repairing the machine, turn off the engine, remove the ignition key and wait until all moving parts have come to a complete stop.

- 21: Do not stand between the tractor and the machine unless the hand brake is tight and/or stops have been placed under the wheels.
- 22: Before any adjustments, maintenance or repairs are carried out, ensure that the machine cannot be started up accidentally.

ADDITIONAL RECOMMENDATIONS FOR LINKAGE MOUNTED MACHINES

- 1: Before attaching the machine, ensure that the front tractor axle is sufficiently ballasted. Ballast is to be placed on the supports provided in accordance with instructions of the tractor manufacturer.
- 2: Do not exceed the maximum axle load or the overall transport weight prescribed by the tractor manufacturer.
- 3: Precision steering, tractor adherence, road holding and efficient braking are influenced by the type of implement, weight, ballast of front axle, ground or road conditions. It is therefore of utmost importance to be cautious in every given situation.
- 4: Be particularly cautious when turning corners, paying attention to machine overhang, length, height and weight.

SAFETY RECOMMENDATIONS FOR ATTACHING IMPLEMENTS TO TRACTOR

- 1: When attaching or removing the machine from the tractor, position hydraulic lift control lever in such a way that it cannot be set off accidentally.
- 2: When attaching the machine to the tractor hydraulic linkage, ensure that diameter of the link pins corresponds to the diameter of the ball joints.
- 3: **WARNING!** Danger of crushing and shearing can exist in the lifting zone of the tractor hydraulic linkage!
- 4: Do not stand between the tractor and the machine when operating the outer lever of the lift mechanism.
- 5: In transport, the machine lift mechanism should be stabilized by tractor tie rods to avoid floatation and side shifting.
- 6: When transporting the machine, lock the hydraulic lift control lever in place so that it cannot be lowered accidentally.

HYDRAULIC SYSTEM

- 1: **WARNING:** Hydraulic system is under pressure.
- 2: When fitting hydraulic motors or cylinders, ensure that connections have been made correctly, as per manufacturers instructions.
- 3: Before connecting hoses to the tractor hydraulics, ensure that tractor and machine circuits are not under pressure.
- 4: It is strongly recommended that the operator marks the hydraulic connections between tractor and machine to avoid making a wrong connection.
WARNING: Functions could be reversed (for example: lift/lower)
- 5: Check hydraulic hoses regularly! Worn or damaged hoses must be replaced immediately. Replacement parts must be in accordance with the manufacturers recommendations concerning specifications and quality.
- 6: Should a leak be found, take all necessary precautions to avoid accidents.
- 7: Any liquid under pressure (particularly oil from hydraulics) can penetrate the skin and cause severe injury. If injured, see a doctor immediately, there could be a danger of infection.
- 8: Before any adjustments, maintenance or repairs are carried out, lower the machine, depressurize the circuit, turn off the engine and remove the ignition key.

MAINTENANCE

- 1: Before checking for any machine malfunction and before adjusting, maintaining or repairing the machine turn off engine and remove ignition key.
- 2: Check tightness of nuts and bolts regularly. Retighten if necessary,
- 3: If the machine is raised, prop it up in a stable position before carrying out any maintenance work.
- 4: When replacing a working part, wear protection gloves and use only standardized tools.
- 5: It is forbidden to discard any oil, grease or filters. These must be given to waste disposal organisations to protect the environment.
- 6: Disconnect power source before any work is done to the electric system.
- 7: Check safety guards regularly, particularly those that are subject to wear. Replace immediately if damaged.
- 8: Spare parts used must be in accordance with specifications and standards as defined by the manufacturer. Use only genuine TANCO parts.
- 9: Before any electric welding is carried out on tractor or attached machine, disconnect generator and battery terminals.
- 10: Repairs on elements under pressure or tension (springs, accumulators etc-) must only be carried out by competent persons with standardized equipment.

SPECIAL SAFETY INSTRUCTIONS

1. Stop engine of tractor before working on machine.
2. Put a suitable prop under raised platform before working in this area.
3. Always raise Lift Arm and fit safety prop before transporting machine on public roads.
4. Lift Arms should always be lowered before operating turntable.
5. Ensure platform rollers are parallel to Lift Arm before arm is raised.
6. On Autowrap models fitted with hydraulic bale ramp it is essential that the hydraulic hose is not disconnected from the hydraulic cylinder or hydraulic accumulator. This system is charged under pressure. Also, do not attempt to open the hydraulic accumulator as this is a pressurised unit.

OPERATING SAFETY INSTRUCTIONS

1. Operators should have their hands on the controls at all times when machine is in use.
2. Autowrap control unit and level controls must remain in the tractor cab at all times. The operator must at no time leave the tractor cab when the machine is in motion.
3. Keep onlookers clear of machine at all times. Danger zone is 5 metres.
4. Beware of rotating turntable and all moving parts.
5. If not operated correctly the bale could fly off the turntable. The end support rollers must always be fitted. Do not exceed recommended turntable speed of 30 r.p.m. Mis-shapen bales combined with excessive turntable speeds can be dangerous.
6. Care must be taken when tipping bales from machine on sloping ground and during subsequent handling to ensure that they do not roll, thus causing hazard.

THINK OF YOUR PERSONAL SAFETY AND THAT OF OTHERS AT ALL TIMES.

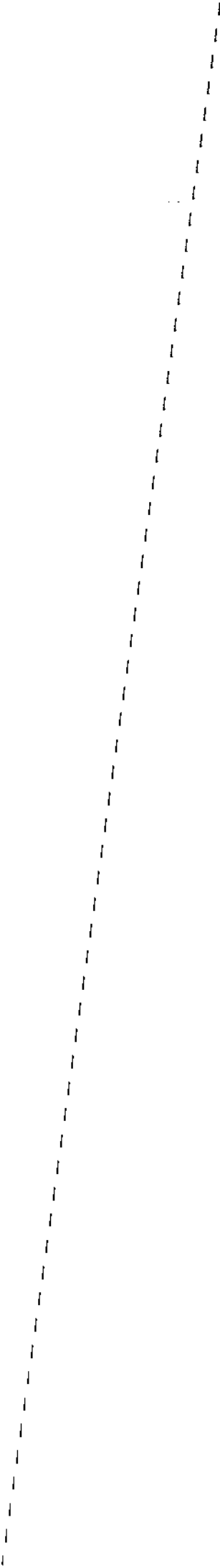

SAFETY DECALS

The following safety decals have been placed on your machine in the areas indicated. They are intended for your personal safety and for the safety of the people working with you. With this manual, walk around your machine and note the content and location of these warning signs. Review these decals and the operating instructions in the manual with your machine operators. Ensure that these decals are always legible. If they are not replace them.

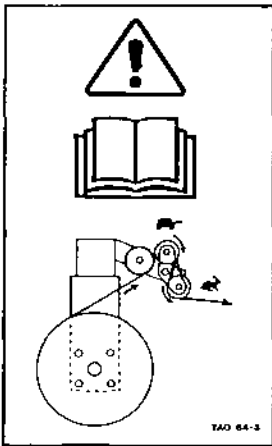
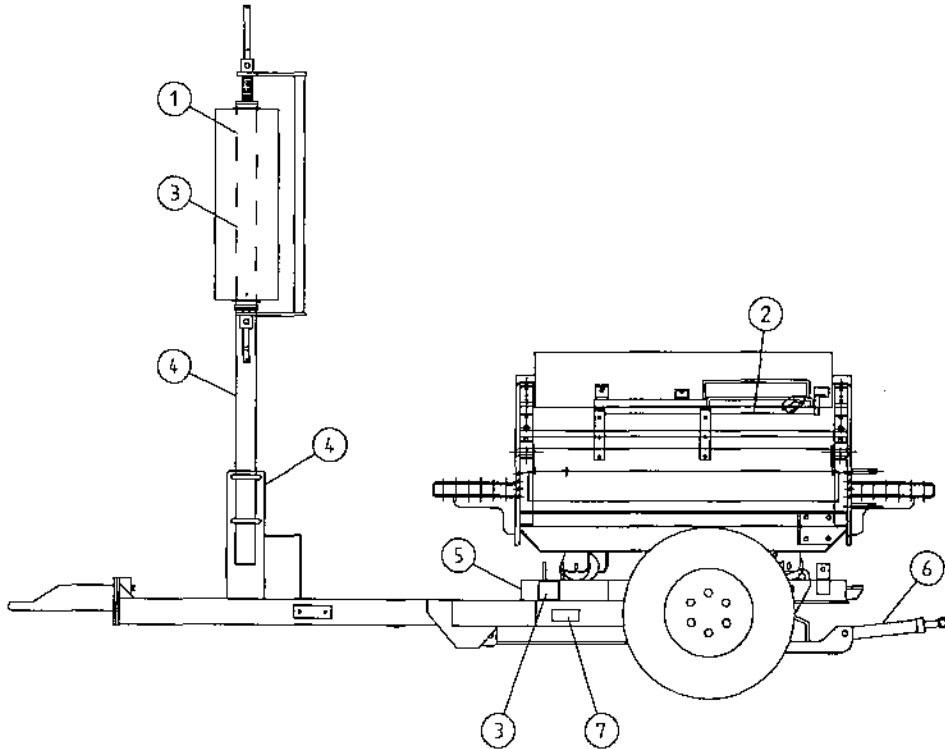

1. READ OPERATORS MANUAL

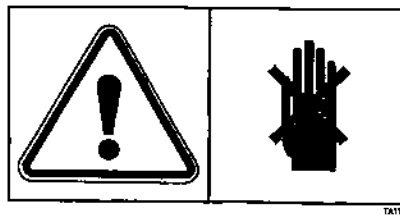

2. WARNING: SHARP BLADE



3. DANGER STAND CLEAR



4. BEFORE STARTING MACHINE
READ OPERATORS MANUAL
AND SAFETY INSTRUCTIONS

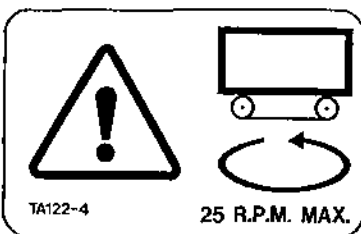

5. DO NOT EXCEED TURNTABLE
SPEED OF 25 R.P.M.



6. BEWARE: HOSES UNDER
PRESSURE AT ALL TIMES



7. ENSURE THAT NUTS ARE
KEPT TIGHT

TECHNICAL SPECIFICATIONS 1060A/1060ATP MODELS (Trailed)

Dimensions	Total Length - Excluding Bale Ramp	350cm
	Width - excluding lift arm	221cm
	Width - lift arm fully raised	243cm
	Width - lift arm lowered	380cm
	Height to top of side (bale guide) rollers	110cm
	Height to top of lift	242cm
Weight	With lift arm	1230kgs
	Without lift arm	1100kgs
Wheels	Size	10-80.12
	Pressure	42 p.s.i.
Lift arm capacity - Axle extended normally		500kgs
Lift arm capacity - Axle extended fully		650kgs
Speed of turntable		25 rev/min*
Oil requirement		23litres/min (165 kp cm ²)
Attachment to tractor		Tractor Hitch
Bale sizes: "Square Bales"		UP to 1.7m
New Holland D1000, D1010		
Welger D4000		
Mengele 530		
Vicon MP 800 M.F.5.		
Hesston 4700, 4750, 4860		
Krone Big Pack 80/80		
Greenland 8080		
John Deere '680		
Bale Sizes: "Round Bales"		1.20m Bales Max 800kg
Film (Width of Roll)		750mm

***The speed of rotation can be varied to suit various conditions but on no account should it exceed 25 r.p.m. (Speeds in excess of 25 r.p.m. will void warranty).**

PRE DELIVERY INSTRUCTIONS

IMPORTANT: DO NOT ATTEMPT TO OPERATE UNTIL THE FOLLOWING INSTRUCTIONS ARE PERFORMED OTHERWISE SERIOUS DAMAGE COULD BE CAUSED

1. MACHINE ASSEMBLY

For ease of transportation some items are removed from their positions and stored elsewhere on the machine. The control box, film dispenser and cut and start unit are stored under the bale belt. Also stored under belt on remote control machines are the infra red receiver and sender units and warning beacon. The film mast is attached to the front of the machine. On round bale machines only, the top rollers c/w mounting brackets and the plastic end rollers are mounted on temporary brackets beside the bale belt. Road wheels, bale lift arm and bale ramp are transported separately. Remove the above items and assemble as detailed in parts list section of this manual taking particular note of the following points.

(i) DISPENSER MAST

Insert lift mast into socket towards front of machine. Ensure film pull down ram is faced towards the machine. Attach the pull down arm hydraulic ram. Attach the film dispenser to the mast ensuring that the end marked top is faced up. On remote control machines attach the infra-red receiver and warning beacon to top of mast. The film mast height is adjustable. Its height is dependant on bale size and type and is set in the field.

It should be set so that centre line of film is in line with centre of bale. See Fig. 1

(ii) CUT & START

Attach Cut & Start unit to mounting frame on the left hand side of the machine. It is possible to move the unit along the mounting and fix it to any of three holes. On all round bale wrapping machines the unit is fixed to the centre hole on the mounting frame. Connect electrical supply to unit ensuring that wiring is secure. The cable is stored on the turntable frame near the Cut & Start mounting.

(iii) BALE LIFT ARM

Assemble bale lift arm and attach to mounting points on right hand side of main chassis. Attach hydraulic ram to lift arm; grease pivot pins.

(iv) TOP ROLLERS AND PLASTIC END ROLLERS

Place plastic end rollers in sockets on the back and front of the turntable. On round bale machines only, attach top rollers and mounting brackets to each side of the machine.

(v) ROAD WHEELS (trailed machines only)

Attach road wheels ensuring that nuts are tight and tyre pressure is 50 p.s.i.

(vi) BALE RAMP OR MAT

Attach bale ramp or mat to rear of chassis. Note Round bale trailed models have bale ramps with an option of hydraulic bale ramp.

Linkage mounted machines have bale mats. The standard 1050 trailed models have hydraulic bale ramps.

SEE INSTRUCTION BELOW FOR FITTING HYDRAULIC BALE RAMP.

CHECKS TO BE PERFORMED

1. Check that all bolts and nuts are tight.
2. That all lubrication points are greased.
3. Check that all guards are in place.
4. Check all operating and safety stickers are in place.

INSTRUCTIONS FOR FITTING HYDRAULIC BALE RAMP

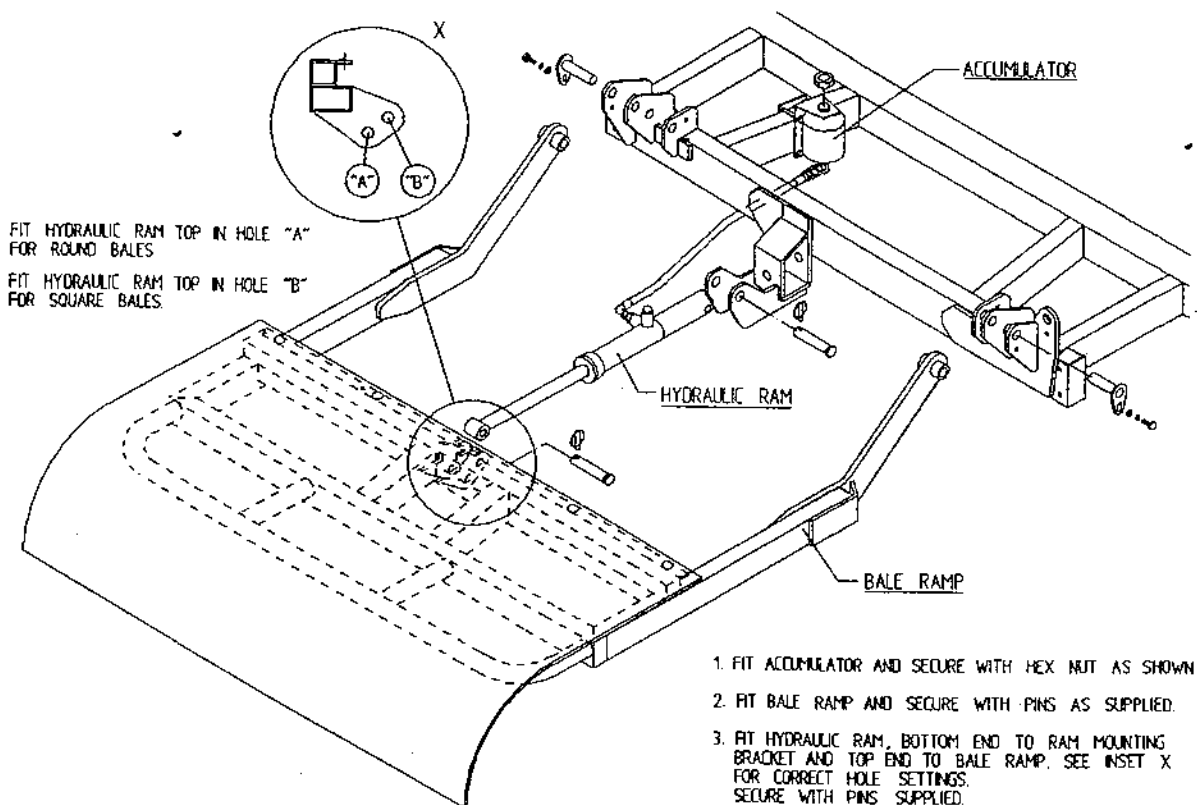

2. OPERATIONAL TEST

When all above assembly and checks have been carried out the operation of the machine should be checked as follows:

NOTE: IF YOU ARE NOT TOTALLY FAMILIAR WITH THE OPERATION OF THE TANCO CONTROL SYSTEM THIS MANUAL IN FULL BEFORE PROCEEDING WITH OPERATIONAL TEST.

1. Attach machine to tractor.
2. Connect hydraulic hoses to D/A service on tractor.
3. Fit controller box inside cab.
4. Connect control box to machine and connect power cable direct to tractor battery. It is important that the leads are connected with the correct polarity.
5. Fit cable control actuator socket to convenient position in cab and locate actuators in socket.
6. Lock hydraulic lever in tractor so that oil is flowing through system.
7. Check function by operating control levers.
 - (a) Lift arm up and lift arm down. **NOTE:** ensure lift arm is down before moving to (b).
 - (b) Turntable rotation forward and reverse.
 - (c) Tip up and down checking hoses are o.k.
8. Switch controller on.
9. Switch controller to manual operating mode by operating toggle switch.
10. Check Cut & Start plunger out and in.
11. Switch machine to AUTO mode then run through the wapping cycle. See operating instruction section of this manual on how the machine should perform, and if any function fails to operate correctly consult fault finding section of the operators manual.

3. CUSTOMER CHECKS

Before despatching consult customer on the following points:

1. That the machine model suits his requirements.
2. If machine is to be operated on a tractor with a closed centre hydraulic system then a closed centre valve is required, see separate instructions.
3. That the tow hitch type is compatible with the tractor. Three different hitch types are available.

TRANSPORT INSTRUCTIONS

1. Never use straps around the machine when lifting. Use only the following lifting points:- Tow hitch and two sockets on each side of main frame at rear for trailed models. 3 pt. Linkage frame and two sockets on each side of main frame at rear for 3 pt. Linkage Model.
2. When the machine is towed on the road the Lifting Arm (if fitted) must be in the fully raised position, the safety prop fitted and the axle returned to narrowest position.
3. Raise the Parking Jack on trailed models before moving machine-

MACHINE IDENTIFICATION

The Serial Number plate is located on main frame forward of offside wheel on trailed models and on 3pt. Linkage frame for 3pt. Linkage model.

Always refer to this number when ordering parts. The Spare parts catalogue number and description should be used. The reference numbers are used to help identifying the spare part.

For your records write serial number here.

SERIAL NO.

PREPARATION OF A NEW MACHINE

1. Check height of film mast to ensure that centre line of film spool is level with the centre line of the bale on the turntable. This will alter with different bale diameters. If this alignment is not correct more film than necessary will be used. See fig 1.
2. When connected to John Deere* tractor the value must be converted to closed centre.

HYDRAULIC CONNECTIONS

Connect the feed and return hoses from the Autowrap valve to the tractors double acting facility.

NOTE: The return hose is fitted with a non-return valve to protect the Autowrap from damage in the event of incorrect connection to tractor hydraulics.

NOTE: To ensure maximum efficiency and length of lift of hydraulic components this machine requires a clean supply of hydraulic oil.

IT IS RECOMMENDED THAT THE TRACTOR HYDRAULIC FILTER ELEMENT TO BE REPLACED AND THEN, AFTER MAINTAINED IN ACCORDANCE WITH THE MANUFACTURERS RECOMMENDATIONS.

TANCO AUTOWRAP 1080A MODEL C/W "TWIN-PAK" LOADING ARM JUNCTION BOX AND CONTROLLER

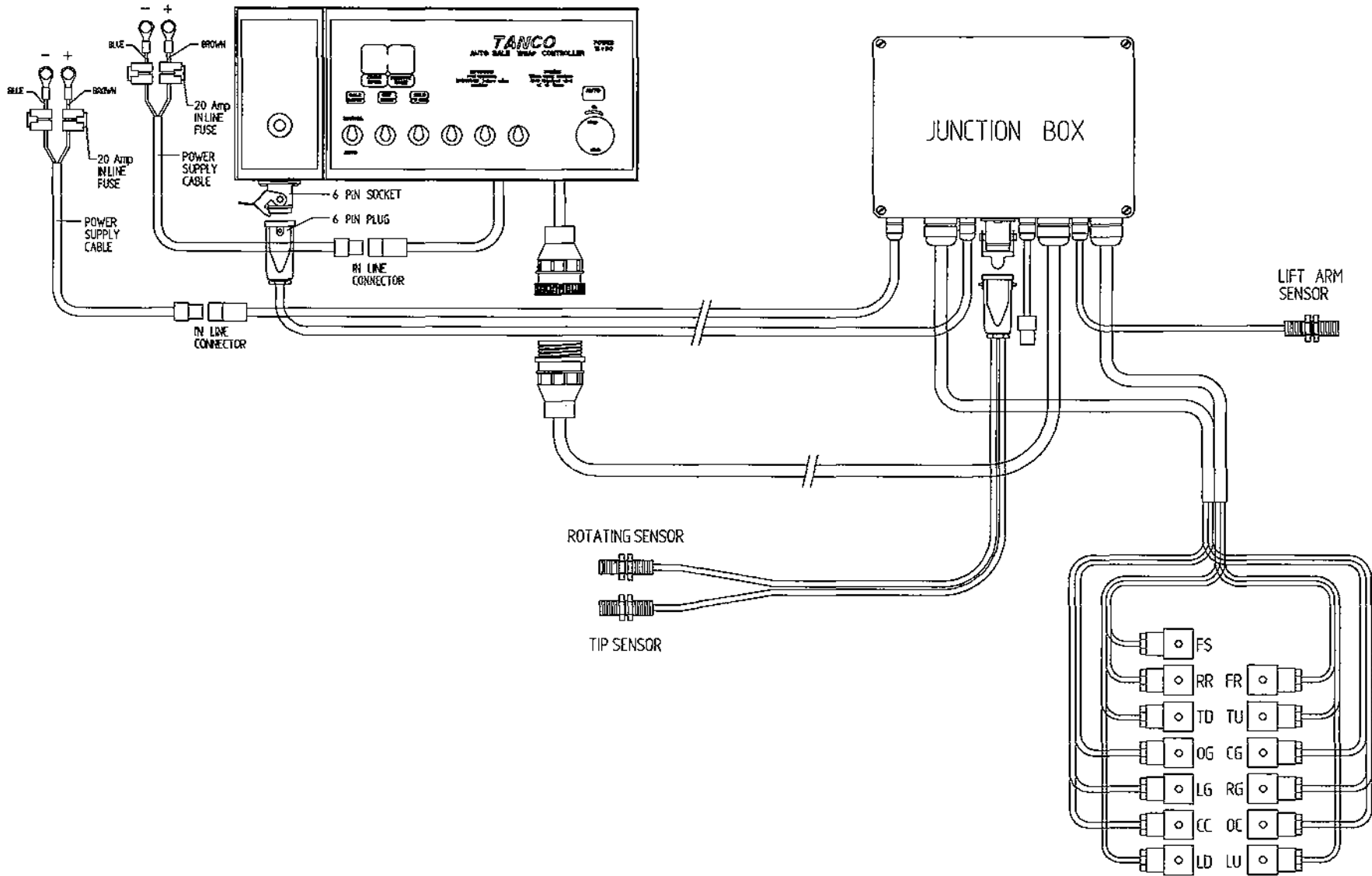

280ARC/580A/1080A/1080ATP

AUTOMATIC BALE WRAP CONTROLLER (issue 116 onwards)

The control unit on the control of the bale wrapping sequence. The control unit is preprogrammed to automatically wrap the bale to the required number of rotations. Once complete, the turntable stops in the correct position to allow the film to be cut and held. Incorporated is also an inching override facility on the control unit to move the turntable, left or right, to ensure that the film is properly gathered. Once the turntable is lowered it rotates automatically forward through 90 degrees to facilitate loading the next bale. For reasons of safety loading and tipping off of the bale is operator controlled using switches on the control unit.

The programming of the Automatic Bale Wrap Controller is easily done by following the steps outlined below.

Once the unit is switched on, the number of required turntable rotations appears on the right hand display. To change this press and hold the "Hold to Set" button, see fig 7., then press the "Set/Reset" button. The first digit of the number will then blink and count from 0-9. Release the "Set/Reset" button at the required number. By pressing the "Set/Reset" again the second digit can be changed.

The monitor counts the number of bales per batch and the cumulative total. To see these, press the "Bale count" button. The first number to appear is the batch total. If the button is held down for 10 seconds, a line will appear on the display, followed by the cumulative number wrapped. The batch count can be reset to 0 by holding the "Bale Count" button down and pressing the "Set/Reset" once. The cumulative total cannot be returned to zero.

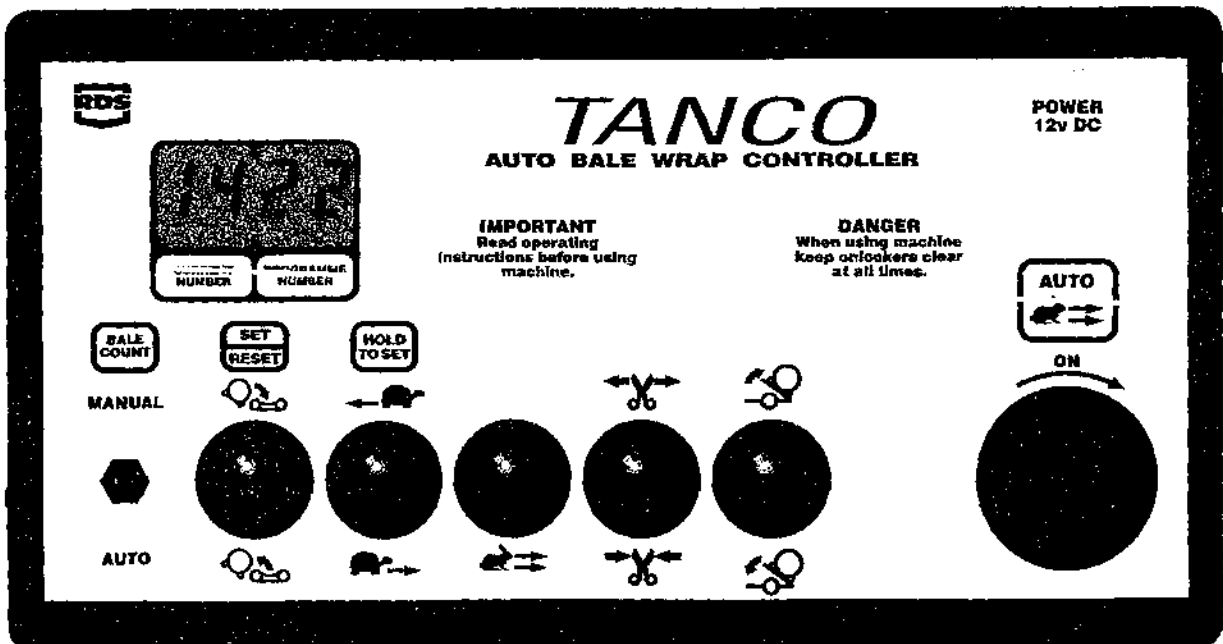

280ARC/580A/1080A/1080ATP OPERATOR ACCESSIBLE MONITOR PROGRAMMES

(Issue 116 Hydraulic Cut and Start)

The Auto Bale Wrap Controller displays a total of 7 programmes. To access the programming mode, turn the power off by pressing the red button, then press and hold the 'hold to set' key and turn the power on, by rotating the red button. Now you have accessed to the programming mode. A chevron 'V' will appear in the left side of the left display - this indicates the first function. By pressing the 'hold to set' key the next program is accessed and so on. The chevron 'V' will move across the display indicating each of the 7 functions. The functions and settings are as follows.

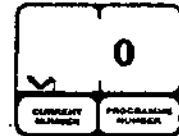

Programme 1: This program does not apply to this model.

Display Reading: 0

Function: This program is factory set and should not be altered



Programme 2: Tip up.

Display reading: 4.0

Function: This controls the time for which the tipping ram extends out after the 'Cut and Start' closes. **Note:** This value requires to be altered only when the setting of the rear magnet that impulses the tip sensor is changed.

- I. If the magnet is adjusted upwards then this value will have to be increased.
- II. If the magnet, is adjusted downwards then this value is decreased. Adjustment is in 0.5 second increments.

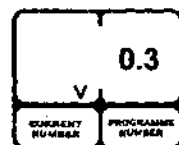

Program 3: Tip up to tip down delay

Display reading: 0.3

Function: Duration in seconds that the tipping ram remains fully extended between tip up and tip down.



Program 4: Tip down.

Display reading: 4.8

Function: This controls the time required for the turntable to return to the horizontal position. **Note:** This value should be increased if the film pull down arm does not retract fully. Adjust in 0.1 increments.

280ARC/580A/1080A/1080ATP

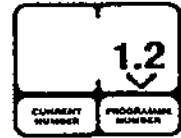

Program 5: Duration of slow rotation at end of wrapping cycle.

Display Reading: 1.2

Function: Shows time that elapses in seconds after turntable magnet passes rotate sensor on last rotation before turntable changes to slow mode. Note: This value need only be altered as follows.

- (i) To increase duration of slow rotation at end of wrapping cycle, reduce this value in 0.1 increments.
- (ii) To reduce duration of slow rotation at end of wrapping cycle, increase this value in 0.1 increments.

Program 6: Machine Operation.

There are six separate settings for this program depending on the model of machine being used. Three of the settings apply to remote control models and three to non remote models.

Non remote control mode with 90 degrees forward function = Symbol **O2**

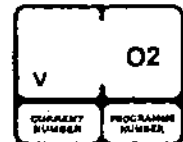

Remote control mode with 90 degrees forward function = Symbol **R2**.

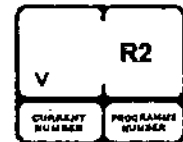

Remote control mode with no 90 degrees reverse or forward function = Symbol **r**

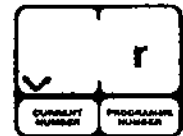

Remote control mode with 90 degrees reverse function = Symbol **R**.

Note: This programme only applies to pre 1999 models of autowrap



Non remote control mode with no 90 degrees reverse or forward function = Symbol **o**.

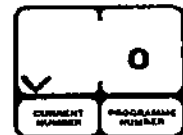

Non remote control mode with 90 degrees reverse function = Symbol **0**.

Note: This programme only applies to pre 1999 models of autowrap

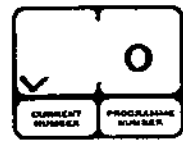

280ARC/ 580A/1080A/1080ARC

Program 7: Tractor hydraulics.

Designed to convert the hydraulic system to open or closed centre hydraulics to suit tractor.

Closed centre = Symbol **J**

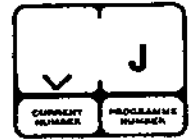

Open centre = Symbol **n**.

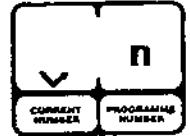

NOTE: An additional valve is required for operating in the J mode.

MODE OF OPERATION

Automatic Mode: with switch in "Auto" Position.

1. Ensure turntable is in correct position to accept bale and that film is gripped by the "Cut and Start".
2. Lower bale lift arm, drive alongside, pick up the bale and raise the lift arm.
3. Allow the bale to roll gently onto the turntable so that it is central between the end rollers.
4. Lower the arm clear of the turntable and press the "Auto" (Start) button commence wrapping.
NOTE: The table must be in the correct position before the "Auto" (Start) button is pressed. If not the table may stop in the wrong position at the end of wrapping.
5. With the controller in Automatic Mode the turntable will start off for half of one rotation in "Slow Mode" before changing to "Fast Mode". During the final rotation it will change to "Slow Mode" and stop in the correct position so that the film is lined up above the open "Cut and Start". NOTE: The turntable can be moved to left or right to align the "Cut and Start" by using the slow rotate switch on the controller or the buttons on the remote control unit.
6. On the third rotation of the wrap cycle the "Cut and Start" will open automatically.
7. When in a safe position to do so, press the "Tip Up" button, the turntable will tip upwards gathering the film on the "Cut and Start" plunger whilst the pull down arm reduces the film to a rope which is cut as the "Cut and Start" closes, cutting the film and gripping the film end in readiness for the next bale.
8. The tip off sequence is automatic and once the turntable lowers it will reverse and stop in position to facilitate loading, if programmed to do so.

Manual Mode: with switch in "Manual" Position

1. Load the bale as outlined above.
2. Using the slow rotation switch. start the wrapping cycle.
3. After half of a rotation, switch to the fast wrapping mode by pressing the appropriate switch.
4. During the wrapping extend the "Cut and Start" out to the end.
5. At the end of the wrap cycle line up the "Cut and Start" with the film.
6. When safe to do so, tip up the turntable until all the film is gathered on the "Cut and Start". Operate switch to close position. the "Cut and Start" will close cutting the film. Continue tipping until the bale rolls off then lower the turntable.
7. Position the turntable to load the next bale.

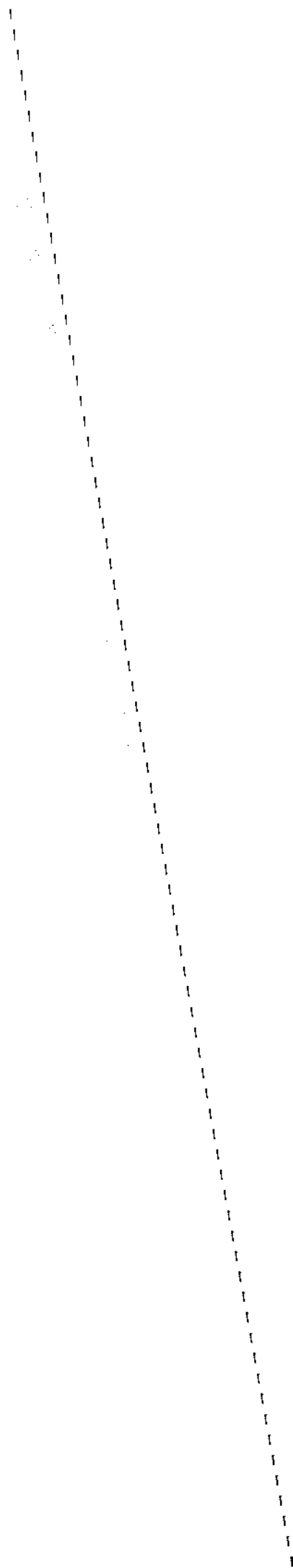

Operating Instructions

1. Fit roll of film and thread through the Dispenser roller assembly by following the instruction label on the film mast.
2. Set the bale wrap indicator to the correct setting for the size of bale being wrapped and the width of film being used. See Table 1 for list of some recommended settings.
3. Power down Lift Arm until wheel is clear of ground and adjust wheel outward to appropriate setting for bale weight.
4. Adjust tractor engine speed to give turntable speed of 16 - 25 r.p.m. NOTE. Speeds in excess of 25 r.p.m. will void Warranty.
5. Position turntable with cut and start unit facing front of machine.
6. Attach film tag end to gripper section of cut and start unit.
7. Rotate turntable anticlockwise through 90 degrees and stop turntable with cut and start unit opposite to lift arm.
8. Locate bale on lift arm, then raise lift arm and gently roll bale onto turntable. Lower arm.
9. Start wrapping, turntable rotating clockwise. Film tension is automatically set so that width of film applied to the bale stays at a constant width of 600mm for 750mm wide film roll.
10. Continue wrapping until signal from bale indicator sounds (required number of revolutions has been reached). Then stop with cut and start facing towards front of machine and film aligned with gripper section of cut and start unit.
11. Tip bale from machine. When the machine is almost fully tipped the cut and start unit grips and cuts the film and the bale is then unloaded down the bale ramp.
12. Lower the turntable and rotate anticlockwise through 90 degrees and stop with cut and start unit opposite to lift arm.
13. Repeat operations 7 - 12 as required.
14. Ensure that 220mm dia idler roller mounting bearing is attached to correct set of mounting holes in mounting bracket to wrap square/rectangular or round bales. See fig A. below.

NOTE: The film end need only be attached at the start of a roll, after that the sequence is automatic.

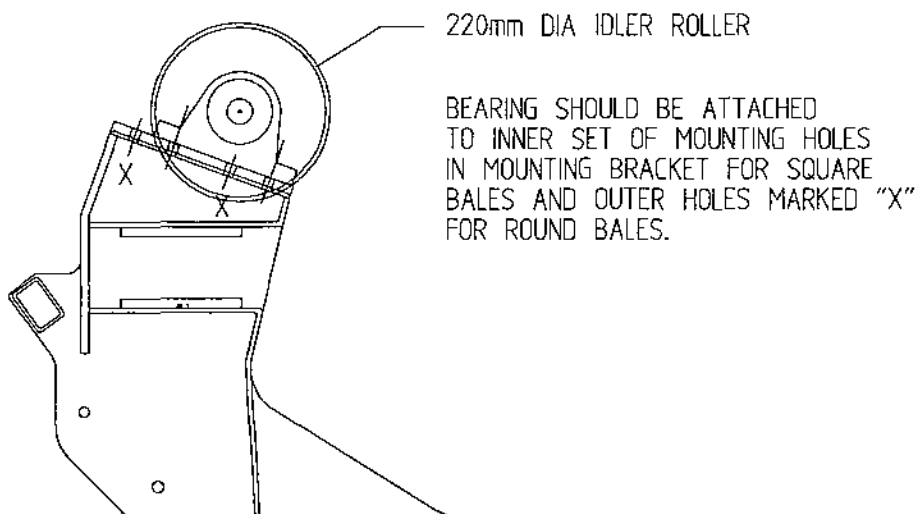

WARNING: LIFT ARM

1. The Lift Arm on the trailed machine is designed to pick up and deposit bales onto the turntable prior to wrapping and to raise the machine while empty, to facilitate adjustment of sliding axle. It is not intended to be used for transporting bales over distances or for use as a stabiliser whilst wrapping.

Therefore any use of the lift arm outside its primary function will be deemed to be abuse and will void all warranty.

2. Before raising loading arm ensure that turntable is in correct position for loading bales so that loading arm will not foul it.

Failure to observe this warning will lead to failure of turntable centre bearing and/or turntable 4" support wheels., which will not be covered by warranty.

**OPERATING INSTRUCTIONS
"TWIN-PAK" LOADING ARM**

The "Twin-Pak" loading arm will lift and load bales of 80cm x 47/50 in pairs, one on top of the other.

If necessary the "Twin-Pak" arm is capable of stacking the bales in pairs itself, before loading on to the wrapper, but it is more efficient if used in conjunction with a bale accumulator.

When handling square or rectangular bales the hydraulic cylinder should be positioned in hole "b" see Fig below.

When handling round bales the hydraulic cylinder will have to be positioned in hole "A".

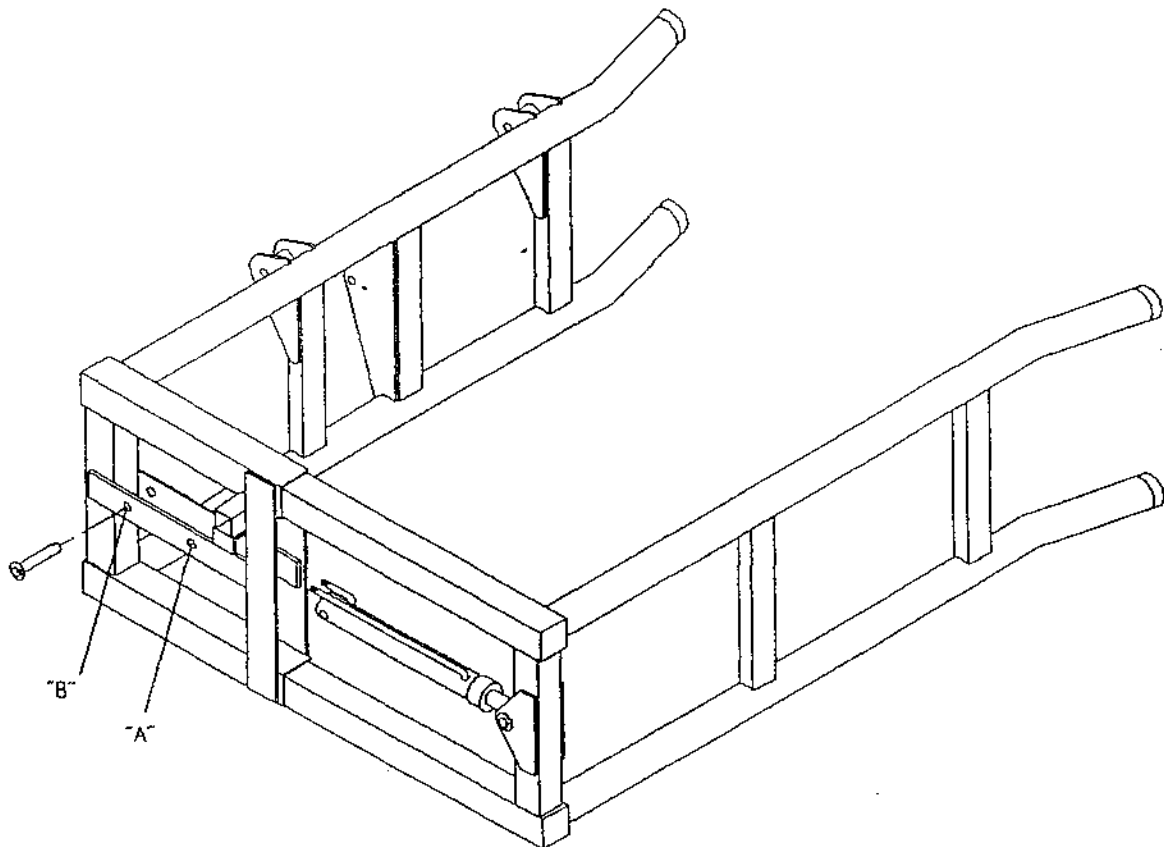

AUTOWRAP 1080 "TWIN-PAK" LOADING SEQUENCE

FIG 1

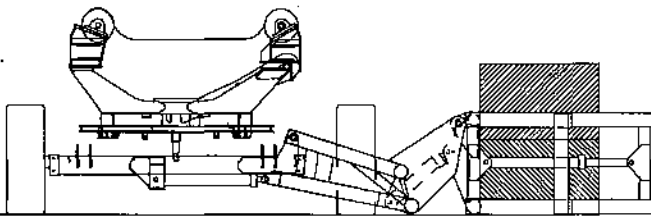

FIG. 1
WITH THE MAIN LOADING ARM DROPPED DOWN SO THAT IT REST LIGHTLY ON ITS SKIDS, WITH OUTER ARM EXTENDED OUT FULLY. DRIVE FORWARD WITH INNER ARM ALONGSIDE THE BALES UNTIL THE BALES COME IN CONTACT WITH BALE STOP.

FIG 2

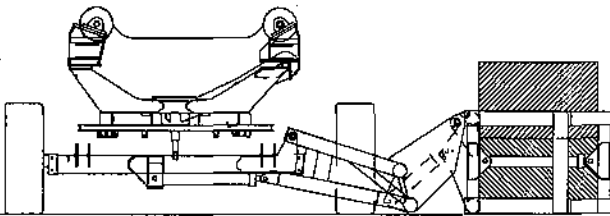

FIG. 2
CLOSE OUTER ARM TO GRIP BALES SECURELY.

FIG 3

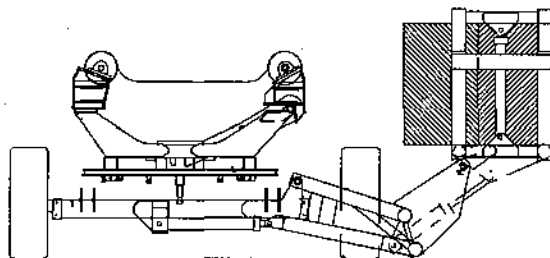

FIG. 3
RAISE GRAB SECTION FULLY AS SHOWN.

FIG 4

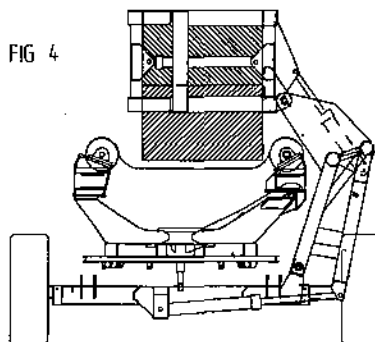

FIG. 4
RAISE LIFT ARM TO POSITION
BALES ON TURNTABLE.
OPEN OUTER ARM TO RELEASE BALES ONTO BELT.

WARNING:

1. THIS LOADING ARM IS DESIGNED TO LOAD BALES WHILE THE WRAPPER IS STATIONARY AND NOT WHILE ON THE MOVE. FAILURE TO OBSERVE THIS WILL LEAD TO PREMATURE BREAK UP WHICH WILL NOT BE COVERED BY WARRANTY.
2. BEFORE RAISING LOADING ARM ENSURE THAT TURNTABLE IS IN CORRECT POSITION FOR LOADING BALES SO THAT LOADING ARM WILL NOT FOUL IT. FAILURE TO OBSERVE THIS WARNING WILL LEAD TO FAILURE OF TURNTABLE CENTRE BEARING, WHICH WILL NOT BE COVERED BY WARRANTY.

FILE NAME: 94025

FILM OVERLAP SYSTEM.

The Autowrap is fitted as standard with the 2 x 2 x 50% film overlap system. The machine is designed so the correct number of film layers are applied to the bale after a specific number of revolutions of the turntable. The number of revolutions required to wrap a bale depends on width of film being used and bale size.

For silage bales we recommend the application of a minimum of four layers of film.

On Square and Rectangular Bales:

20 Revolutions of Dispenser Mast approximately applies 4 layers of film.

30 Revolutions of Dispenser Mast approximately applies 6 layers of film.

IMPORTANT

The above recommendations are only offered as a guide to correct wrapping of silage bales and the manufacturer accepts no responsibility for variations that may arise and the consequence of same. They are based upon turntable speed of up to 30 r.p.m., and a film width of 600mm applied to end of Bale when using 750mm wide film roll.

It is the responsibility of the operator to ensure the correct number of wraps are applied, as variances can occur with fluctuations in speed of rotation, film quality and tensioning, shape and density of bale, field conditions and crop type.

SERVICE AND MAINTENANCE.

- 1: All nuts and bolts should be tightened after one hour 'm use and thereafter regularly.
- 2: Wheel pressure should be normally kept at 42 psi depending on bale weight and field conditions.
- 3: Inspect moving parts for wear on daily basis.

4: Lubrication.

Drive chain & sprocket	Grease every 24 hours.
Main rollers	Grease every 24 hours.
Hinge pins on Lift Arm	Grease every 24 hours.
Hinge pins on main tip frame	Grease every 24 hours
Hydraulic rams	Grease every 24 hours.
Film spool assy	Grease every 24 hours.
Dispenser gearboxes	One shot of Grease every, 500 bales. See 6.
Main spindle	Grease even 4000-5000 bales.

5: Adjustments.

Turntable Drive chain:	Adjust after first days work then check/adjust every 50 hours. See Fig. 8
Gearbox Drive chain:	Adjust after first days work then check/adjust every 50 hours. See Fig. 2
Roller Drive chain:	Adjust after first days work then check/adjust every 50 hours. See Fig. 3
Main Bale Belt:	See belt tracking instructions.

6: Film Dispenser.

Fit with marked gearbox at top.

Apply one shot of grease every 500 bales Use only **NLGI 0 GRADE LITHIUM GREASE**. We reconunend SILKOLENE G46 SL EP grease or approved equivalent, i.e. ESSO BEACON EPO. Wash rollers often to avoid build up of Tack from film using petrol. Follow film threading diagram. See Fig. 1.

7: Film Adiustment.

Centre of film roll must be in line with centre of bale and film mast should be vertical.

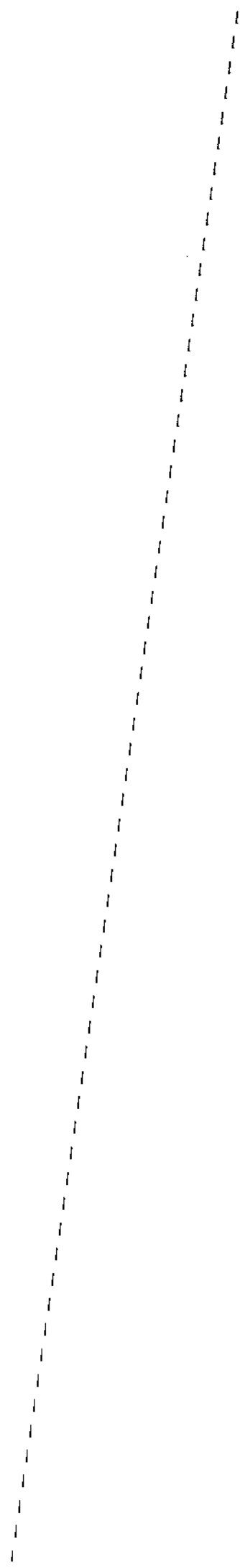

8: Shear Pins

There are two shear pins fitted to sprocket assembly on drive roller see fig 5. If the pins shear, remove the broken pins re-align holes and fit two replacement spiral pins, 6mm dia x 20m long, Din 7344 There are two spare shear pins attached to inside of chain guard.

NOTE: If shear pins are replaced with other than specified above all warranty is null and void.

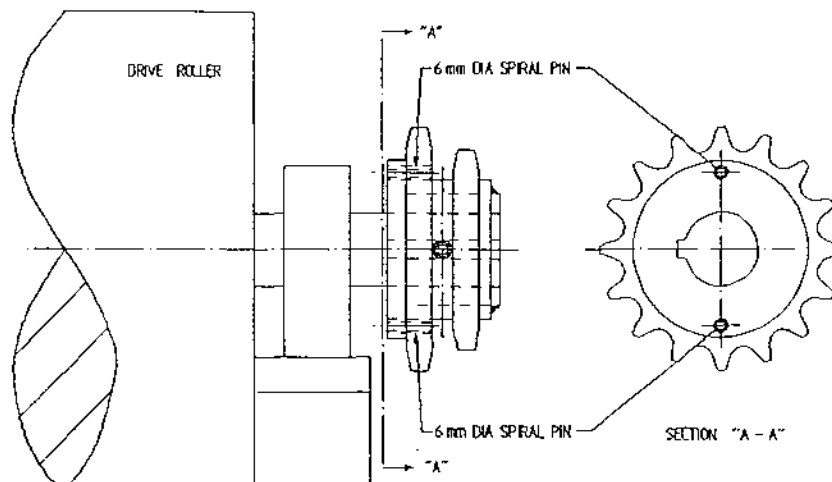
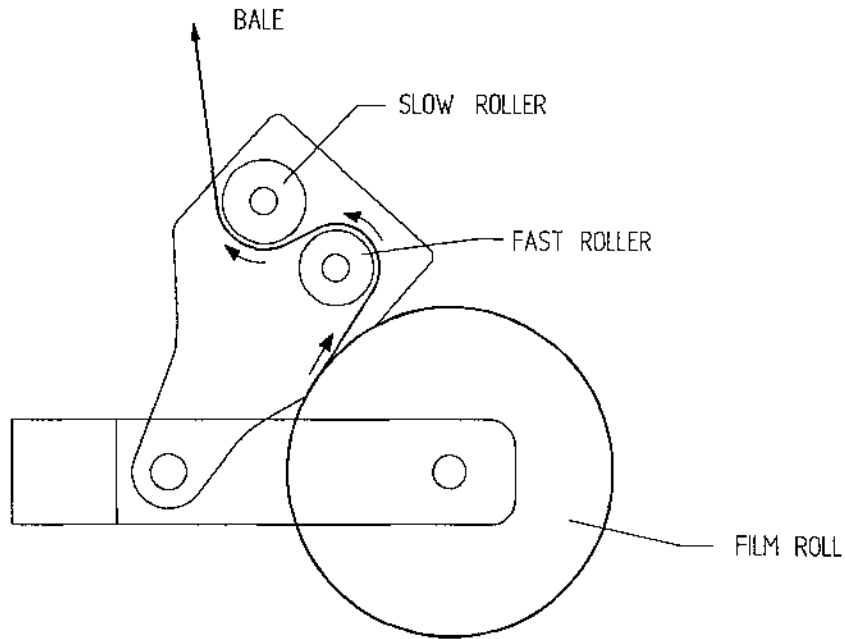

FIG. 5

SERVICE AND MAINTENANCE (CNT.) HYDRAULIC FILTER

1. Before connecting Autowrap to tractor, change oil in tractor hydraulic system and replace hydraulic filter.
2. After 25 hours max. it will be necessary to replace the element in Autowrap filter.
3. For maintenance purposes it is necessary to change the element after 200 working hours.
4. The element cannot be just cleaned and put back into the filter.

TANCO AUTOWRAP FILM THREADING DIAGRAM



FILM ADJUSTMENT

CENTRE OF FILM ROLL MUST BE IN LINE WITH CENTRE OF BALE AND MAST SHOULD BE VERTICAL.

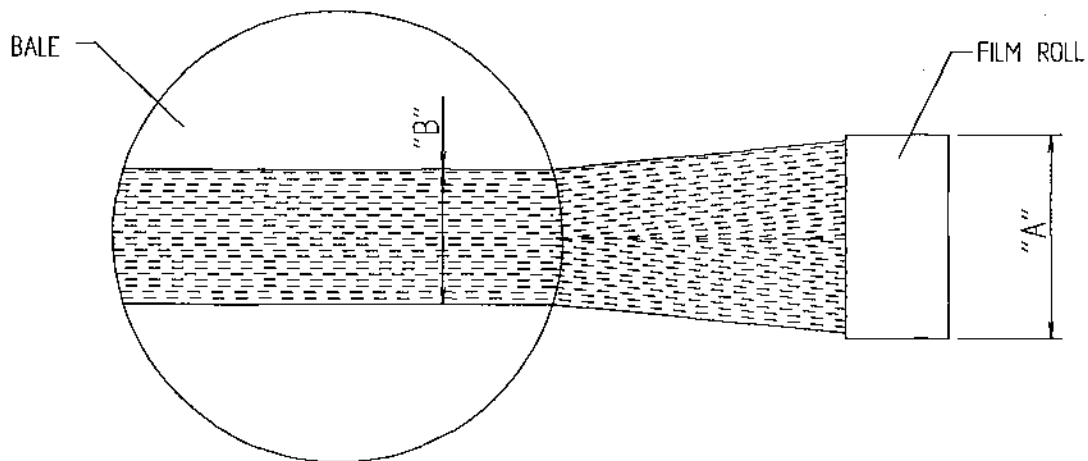

FILM ROLL WIDTH "A"	FILM WIDTH ON END OF BALE "B"
500 mm	400 mm
750 mm	600 mm

Fig. 1

FILE NAME W060-LA21

TANCO AUTOWRAP CONSTANT INDEXING GEARBOX CHAIN DRIVE TENSIONING SYSTEM

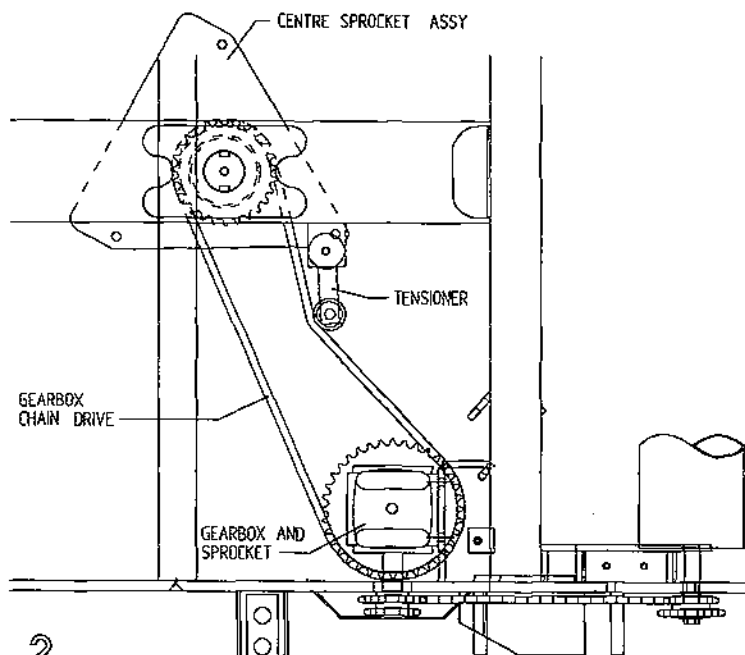

Fig. 2

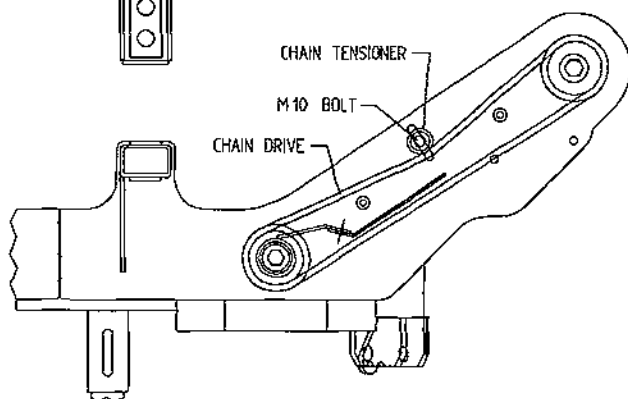
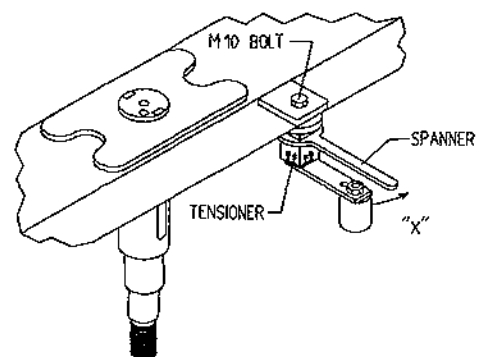

Fig. 3

CHAIN TENSIONING PROCEDURE

1. LOOSEN M10 BOLT SECURING CHAIN TENSIONER.
2. TENSION CHAIN BY ADJUSTING TENSIONER USING SPANNER IN DIRECTION OF ARROW "X" UNTIL SETTING OF 15'-20" IS REACHED.
3. RE-TIGHTEN M10 BOLT TO SECURE TENSIONER IN POSITION.



ROLLER CHAIN DRIVE TENSIONING SYSTEM

CHAIN TENSIONING PROCEDURE

1. LOOSEN M10 BOLT SECURING CHAIN TENSIONER
2. TENSION CHAIN BY MOVING CHAIN TENSIONER INWARDS IN SLOT
3. RE-TIGHTEN M10 BOLT TO SECURE TENSIONER IN POSITION.

TANCO AUTOWRAP TURNTABLE CHAIN DRIVE TENSIONING SYSTEM

TENSIONING PROCEDURE

1. TIP UP MACHINE AND SUPPORT WITH A PROP.
2. REMOVE CHAIN GUARD.
3. SLACKEN M12 CLAMPING BOLTS SLIGHTLY.
4. SLACKEN LOCKNUT A.
5. ADJUST NUT B UNTIL THERE IS 8mm - 10mm DEFLECTION ON CHAIN.

NOTE WARNING:
DO NOT OVER TENSION CHAIN AS MOTOR WILL BE DAMAGED

6. TIGHTEN LOCKNUT A.
7. TIGHTEN M12 CLAMPING BOLTS.
8. REFIT CHAIN GUARD.

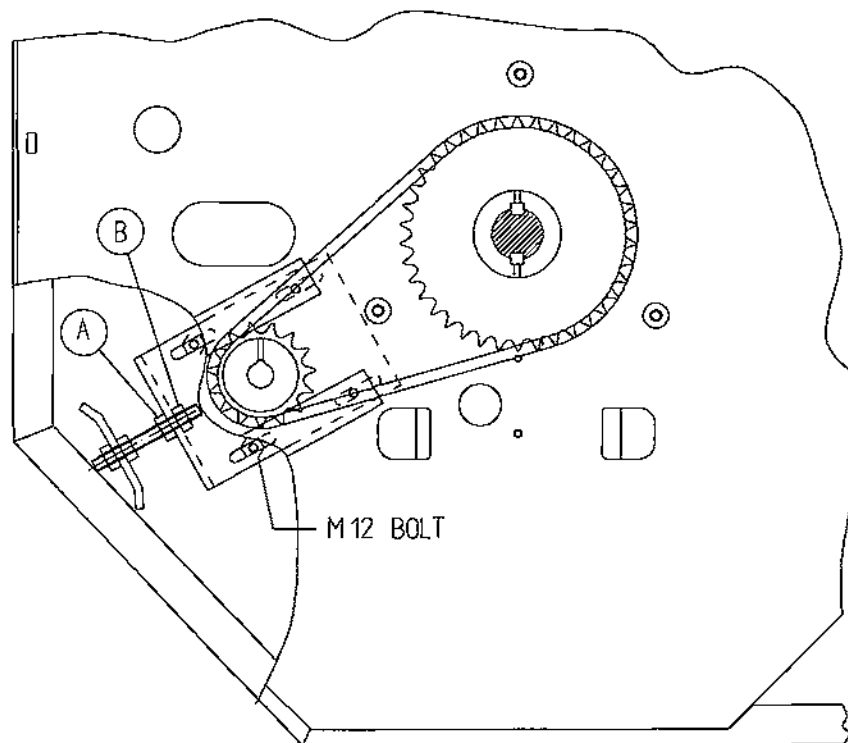

Fig. 8

FILE NAME WD64-LA2

TANCO AUTOWRAP 1080 MODELS BALE BELT TRACKING

This machine is fitted with a continuous belt which has a natural tendency to float due to variations in bale shape centrifugal forces etc. However if the following instructions are followed closely the final setting for tracking the belt can be arrived at over a maximum of two or three bales in the field. The ideal settings will ensure that the belt will always return to a central line

Prior to despatch from our works the belt is centralised on the machine and the belt adjuster and belt tracking rollers are adjusted to the settings on the drawing B.T.I attached.

The belt adjuster roller (item 1) is initially set slightly offset to the drive roller, see A & B. Its primary function is to control the sag in the belt so that the centre of the bale is high enough to ensure that it is fully wrapped correctly on the ends but may also require adjustment to control the belt on the drive roller (see belt tracking procedure below).

The belt tracking roller is purposely set out of line to the top roller, see C & D. Its functions to put tension on one side of the belt to counteract the tendency of the belt to move sideways. The bale will always try to move away from the chain drive side of the machine until it touches the plastic end roller at the other side, at which point the bale will attempt to move away from the bale and towards the chain drive side.

The degree of offset of the tracking roller (item 2) may need adjustment to control the belt on the idler roller.

BELT TRACKING PROCEDURE

1. Ensure the belt tracking roller is adjusted to the initial settings at C & D, (see drawing), and that the belt adjuster roller is adjusted to settings at A & B.
2. Load bale and rotate turntable for approx. 20 revolutions without film being applied and observe if belt moves.
3. If the belt moves more than 30mm out of line, observe which roller it moves on and in which direction it moves then adjust the appropriate roller inwards on the side the belt moves away from in 5mm increments until the belt stays relatively central.
4. Attach film and commence wrapping the bale manually whilst making adjustments as per 3 above.
5. Tip off bale then fresh bale and again wrap using manual controls. If adjustments have not been excessive on any one roller then the belt should now run central.
6. Load next bale and commence wrapping in auto mode whilst observing how the belt behaves. If the belt movement is less than 30mm on either roller do not adjust again but continue wrapping bales.

NOTE: The belt will always move because each bale is different, but provided it runs reasonably central it should not require any further adjustments.

1080 AUTOWRAP BALE BELT TRACKING

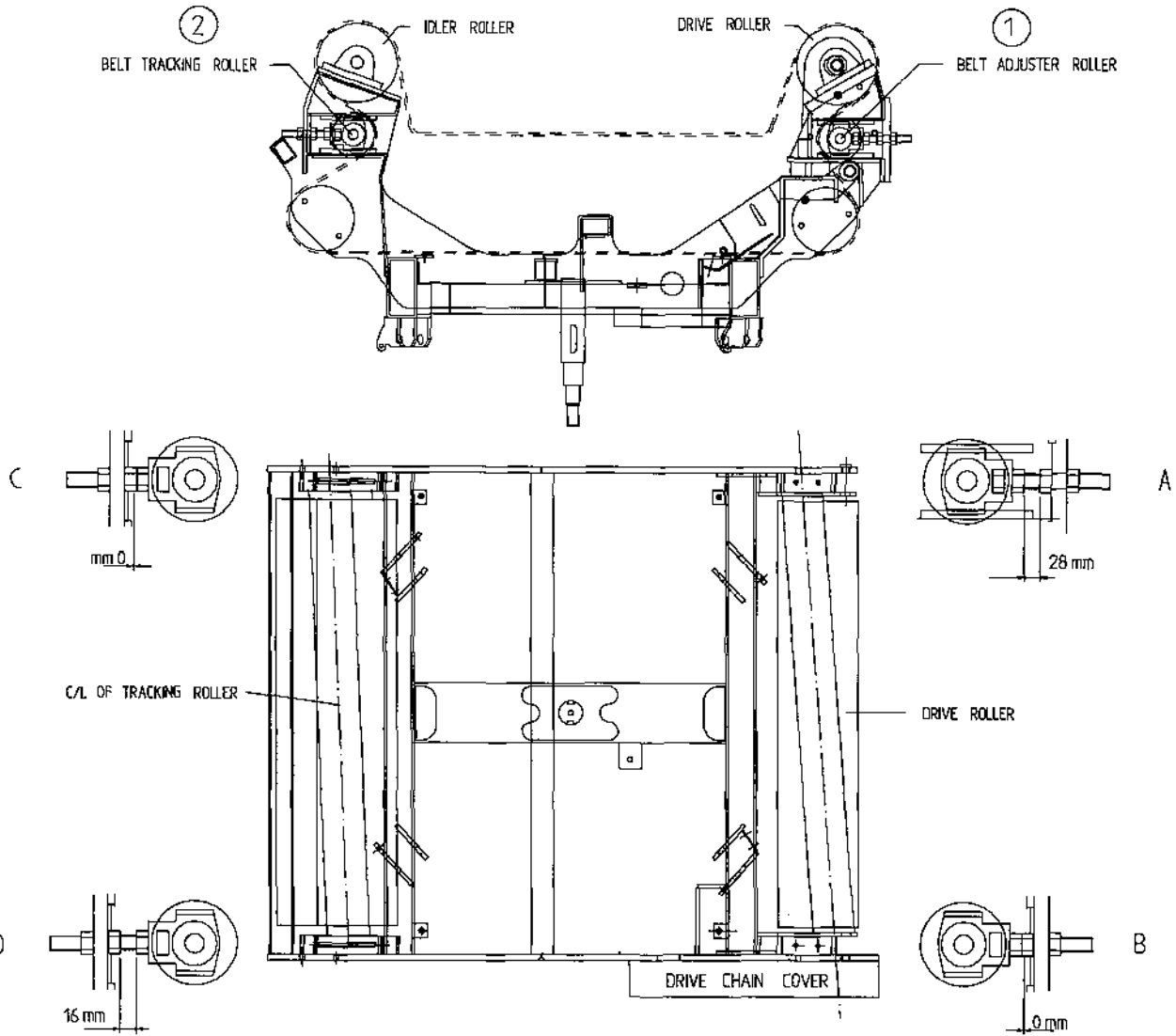

B.T. 1

FILE NAME 9228 A

TANCO AUTOWRAP 1080 ATP MODEL ELECTRICAL COMPONENTS

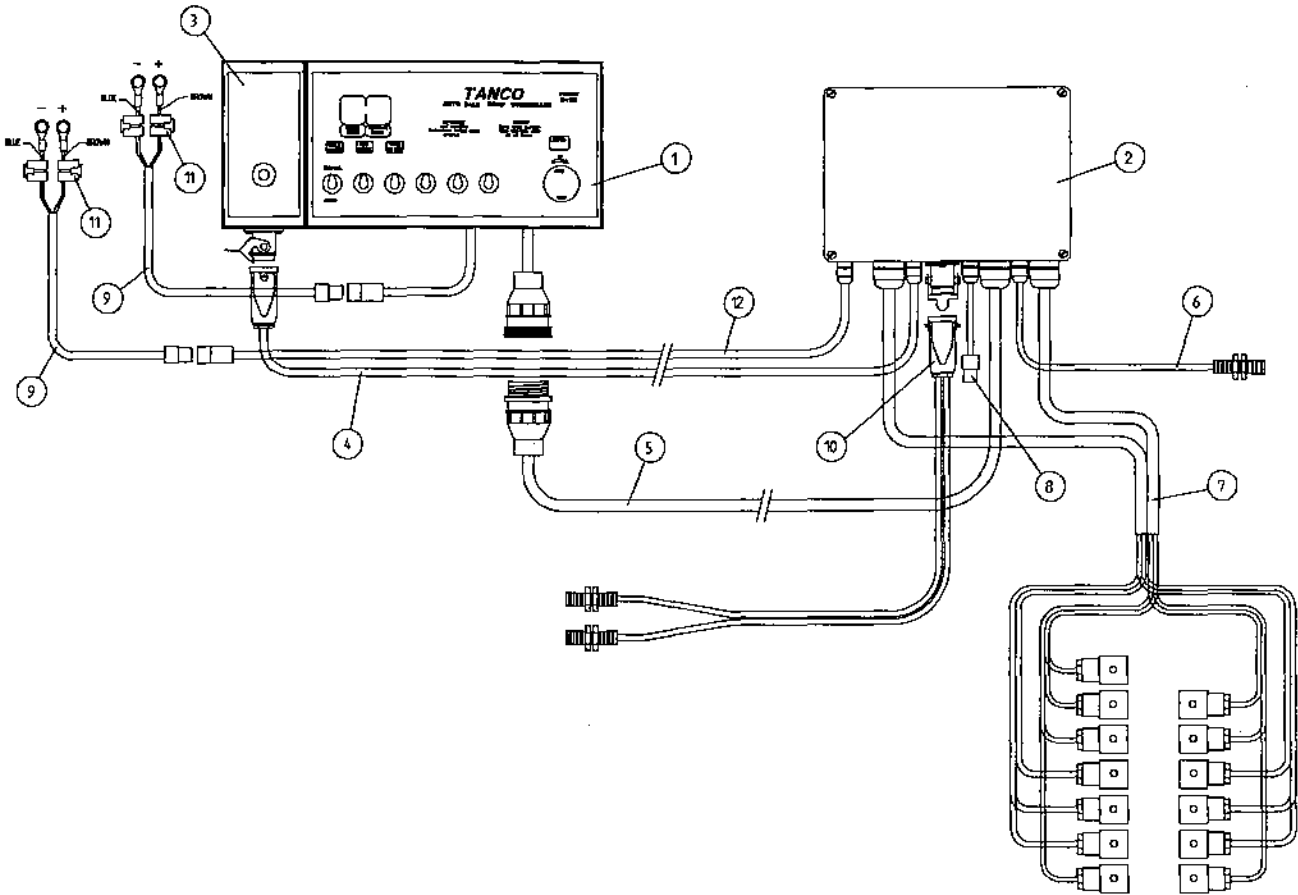

ITEM NO	DESCRIPTION	QTY	PART NO.
1	CONTROL BOX	1	D606
2	JUNCTION BOX (5 BANK VALVE)	1	ZDG-ATP
3	ADDITIONAL CONTROL BOX FOR 1080 MOD	1	ZDG-RCB
4	LEAD FOR ADDITIONAL CONTROL BOX C/W HEARTING PLUG.	1	ZDG-CB
5	24 CORE INTER CONNECTING LEAD C/W CONNECTORS	1	D605-24C
6	LIFT ARM SENSOR	1	ZD606-IAS
7	LOOM FOR VALVE C/W HIRCHMANN	1	ZD606-083H
8	SYSTEM PRESSURE LEAD	2	ZD605-070
9	MAIN BATTERY LEAD	1	ZD606-030
10	TWIN SENSOR LEAD C/W HEARTING PLUG	4	D605-7C
11	IN-LINE FUSE	4	ZD606-075
12	MAIN LEAD FOR JUNCTION BOX	1	ZD606-050

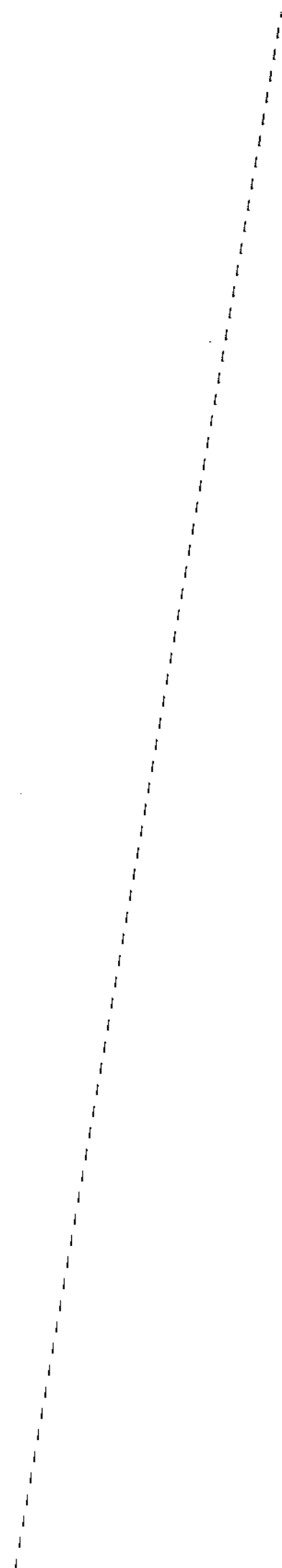

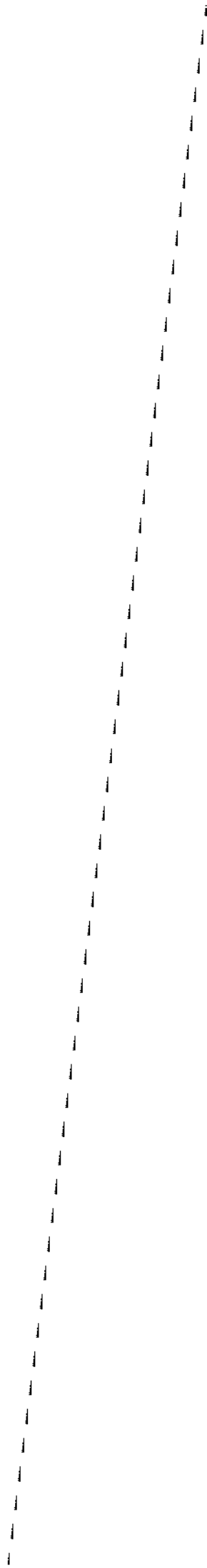

TANCO AUTOWRAP 1060 ATP MODEL "TWIN-PAK" HYDRAULIC CIRCUIT DIAGRAM

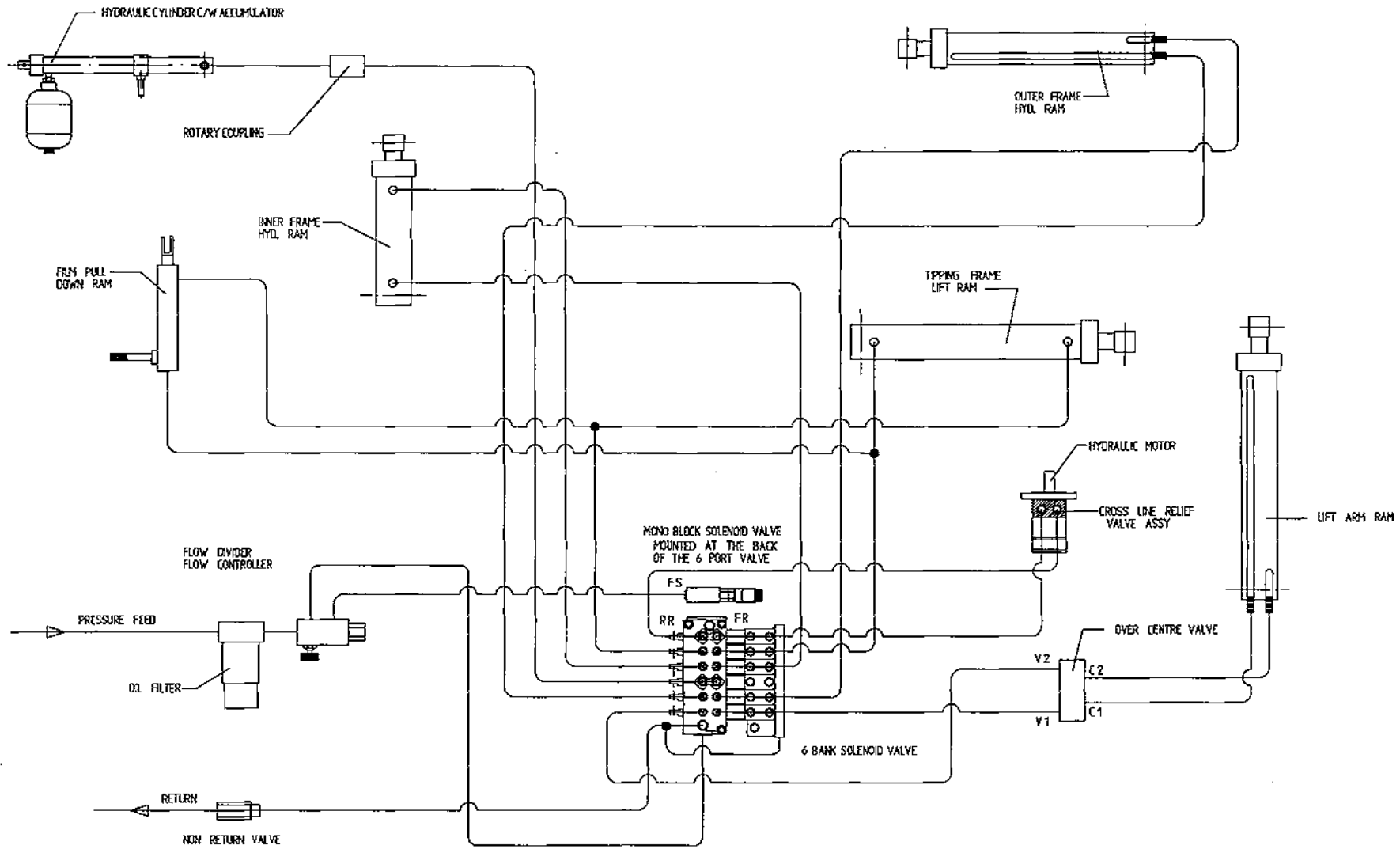

RR
FR ELECTRICAL CONNECTIONS
FS

TANCO AUTOWRAP 1080ATP MODEL - "TWIN-PAK" HYDRAULIC COMPONENTS

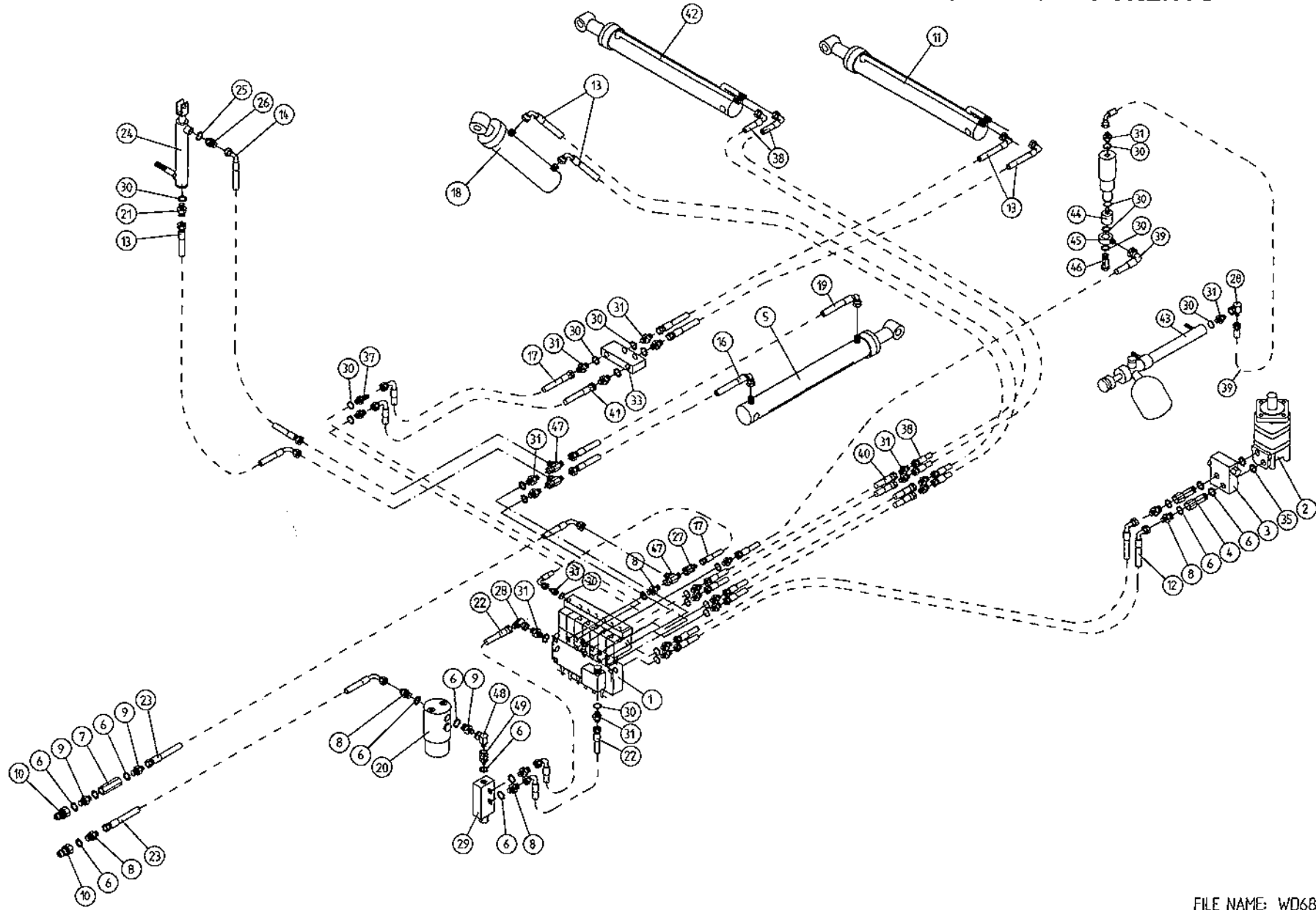

**TANCO AUTOWRAP 1080-ATP MODEL
'TWIN PAK' HYDRAULIC COMPONENTS
PARTS LIST**

ITEM NO.	DESCRIPTION	QTY	PART NO
1	6 BANK SOLENOID VALVE	1	Z01-03-A1060T
2	HYDRAULIC MOTOR C.L.	1	Z01-02-RF200
2A	SEAL KIT FOR ABOVE	1	Z01-RF-200
3	CROSS LINE RELIEF VALVE	1	Z01-03-004
4	1/2" B. S. P. BOTTOM BANJO BOLT (SPECIAL)	2	Z01-03-002B
5	HYDRULIC RAM (TIPPING FRAME)	1	Z01-01-AR687
5A	SEAL KIT FOR ABOVE	1	Z01-Z01
6	1/2" DOWTY WASHER	11	Z01-04-03
7	1/2" NON RETURN VALVE	1	Z01-03-017
8	1/2" x 3/8" ADAPTOR	4	Z01-06-06-08
9	1/2" x 1/2" ADAPTOR	3	Z01-06-08-08
10	1/2" MALE END Q/R COUPLING	2	Z01-15-081
11	HYD. RAM (FOR LIFT ARM)	1	Z01-01-AW
11A	SEAL KIT FOR ABOVE	1	Z01-Y01
12	108" ST/90 3/8" D/W HOSE	2	Z38-R2-108-S9
13	72" ST/90 3/8" D/W HOSE	5	Z38-R2-72-S9
14	84" ST/90 3/8" D/W HOSE	1	Z38-R2-84-S9
15	24" ST/90 3/8" D/W HOSE	2	Z38-R2-24-S9
16	36" ST/90 3/8" D/W HOSE	1	Z38-R2-36-S9
17	12" ST/90 3/8" D/W HOSE	1	Z38-R2-12-S9
18	HYD. RAM (INNER FREAME)	1	Z01-01-DA980
18A	SEAL KIT FOR ABOVE	1	Z01-Y01
19	48" ST/90 3/8" D/W HOSE	1	Z38-R2-48-S9
20	FILTER	1	Z01-24-08
20A	FILTER ELEMENT	1	Z01-24-08E
21	3/8" x 3/8" ADAPTOR FITTED WITH 0.06" RESTRICTOR	1	Z01-03-40
22	12" ST/90 3/8" D/W HOSE	2	Z38-R2-12-S9
23	108" ST/90 1/2" D/W HOSE	2	Z12-R2-108-S9
24	HYD RAM D/A (PULL DOWN ARM)	1	Z01-01-AW25
24A	SEAL KIT FOR ABOVE	1	Z01-AW25
25	1/4" DOWTY WASHER	1	Z01-04-01
26	1/4" x 3/8" ADAPTOR	1	Z01-06-04-06
27	3/8" MALE x 3/8" FEMALE ADAPTOR	2	Z01-05-06-06
28	3/8" MALE/FEMALE 90 ELBOW	2	Z01-14-015
29	IN LINE FLOW DIVIDER	1	Z01-03-10-A6
30	3/8" DOWTY WASHER	22	Z01-04-02
31	3/8" x 3/8" ADAPTOR	20	Z01-06-06-06
33	OVER CENTRE VALVE	1	Z01-03-10-A8
35	COPPER WASHER	2	Z01-04-15
37	3/8" BULKHEAD ADAPTOR	1	Z01-06-05-06
38	120" ST/90 3/8" D/W HOSE	2	Z38-R2-120-S9
39	96" ST/90 3/8" HOSE	2	Z38-R2-96-S9
40	48" ST/ST 3/8" D/W HOSE	4	Z38-R2-48-SS
41	14" ST/90 3/8" D/W HOSE	2	Z38-R2-14-S9
42	HYD RAM (FOR SQUEEZ ARM)	1	Z01-01-AW107
42A	SEAL KIT FOR ABOVE	1	Z01-Y01
43	CUT AND START RAM	1	Z01-01-AWH9
43A	SEAL KIT FOR ABOVE	1	Z01-AWH
44	ROTARY COUPLING	1	Z01-02-AWR
45	3/8" BANJO COUPLING	1	Z01-19-062
46	3/8" SINGLE TOP BANJO BOLT	1	Z01-20-062
47	3/8" ~E x 3/8" MALE x 3/8" FEMALE T'PIECE	2	Z01-12-002
48	1/2" MALE x 1/2" FEMALE 90 ELBOW	1	Z01-14-016
49	318" MALE x 1/2" FEMALE ADAPTOR	1	Z01-05-06-08

**INSTRUCTION FOR FITTING TWO WAY SOLENOID VALVE CLOSED CENTRE
CONVERSION KIT TO TANCO AUTOWRAP 1080A / 1080ATP MODELS.**

REQUIRED WHEN OPERATING MACHINES ON TRACTORS WITH CLOSED CENTRE
HYDRAULIC SYSTEMS.

1. Disconnect St/19'm hose from inlet port on oil filter.
2. Connect port "T" on solenoid valve assembly to inlet port on oil filter.
3. Reconnect St/90 hose to port "P" on solenoid valve.
4. Connect 2 pin female connector to existing 2 pin connector at junction box.
5. Change the seventh controller function setting from n to J. See instruction manual for further information.

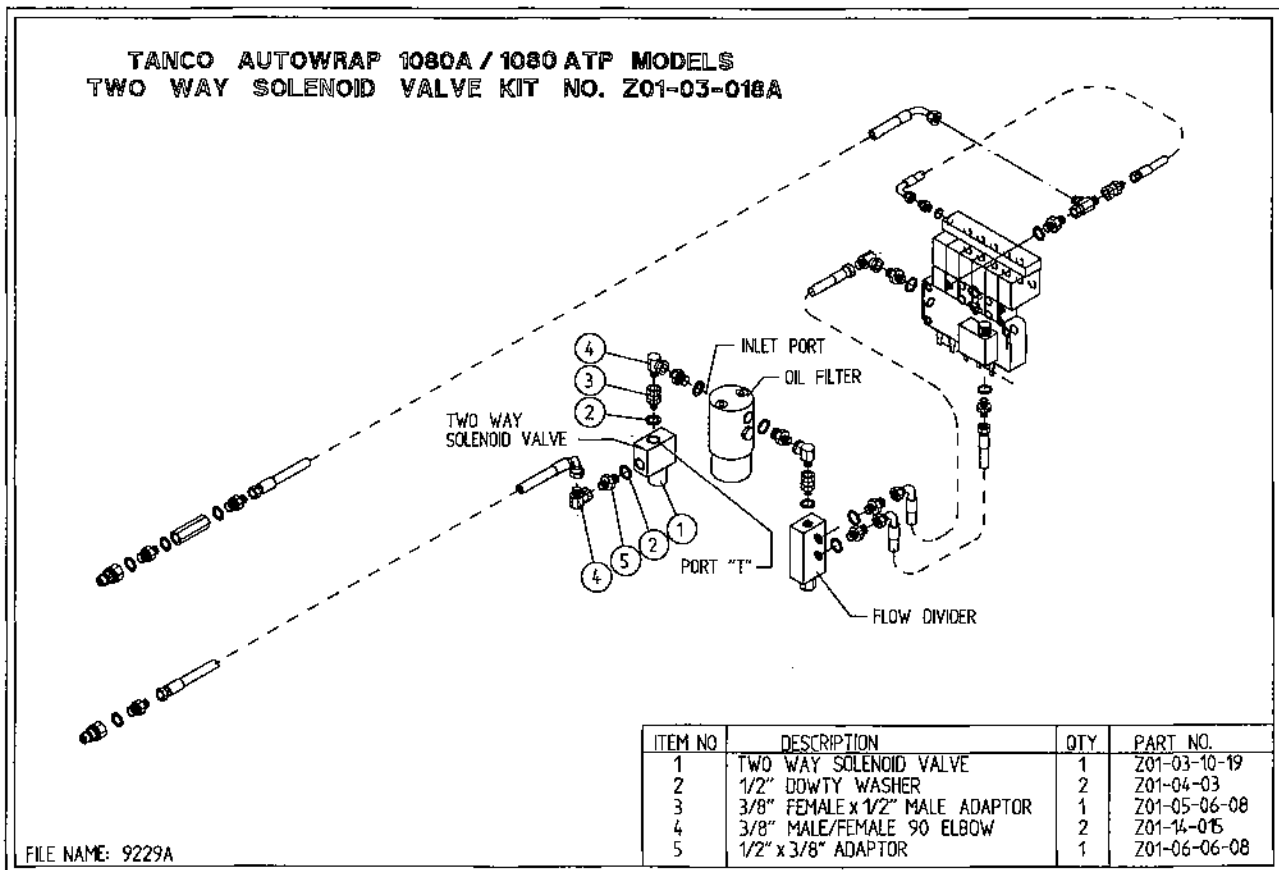

TANCO AUTOWRAP 1080 MODEL CONSTANT INDEXING DRIVE ASSY

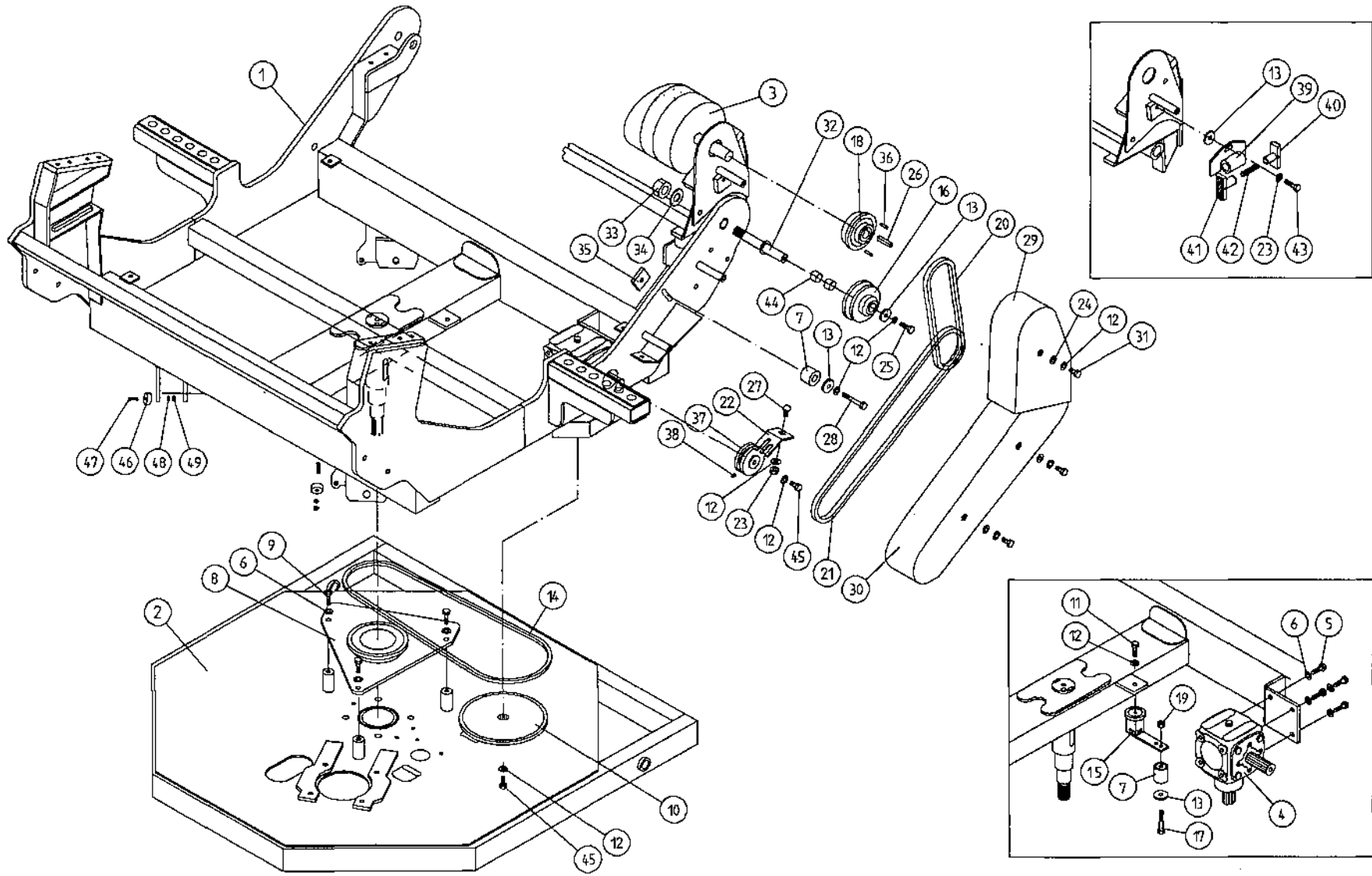

FILE NAME WD90 - PL32

**TANCO AUTOWRAP 1080 MODEL
CONSTANT INDEXING DRIVE ASSEMBLY
PARTS LIST**

WD90PL32

ITEM NO	DESCRIPTION	QTY	PART NO
1	TURNTABLE ASSY	1	WD90-TA
2	TIPPING FRAME ASSY	1	WD67-TF
3	DRIVE ROLLER ASSY	1	WD610-BRD1
4	GEAR BOX	1	Z0I-25-300
5	M12 HEX HD SET x 30mm LONG	4	Z26-082S
6	12mm DIA SPRING WASHER	7	Z12-02-12
7	CHAIN TENSIONER	2	WD60-CT
8	CENTRE SPROCKET ASSY 27 TOOTH	1	WD64-CSA
9	M12 HEX HD SET x 25mm LONG	3	Z26-081S
10	46 TOOTH SPROCKET	1	Z06-D64-46S
11	M10 HEX HD SET x 25 mm LONG	1	Z25-0611S
12	10mm DIA SPRING WASHER	8	Z12-02-01
13	RETAINING COLLAR	4	WD623-071
14	CHAIN 3/4" PITCH x 101 PITCHES	1	Z09-AW-56
15	ROSTA TENSIONING UNIT ARM	1	Z06-454
16	SPROCKET	1	Z06-D610-1620
17	M10 HEX HD BOLT x 65mm LONG	1	Z26-0671B
18	SPROCKET	1	Z06-D610-20K
19	M10 LOCKNUT	1	Z23-10
20	CHAIN 3/4" PITCH x 50 PITCHES	1	Z09-AW-52
21	CHAIN 3/4" PITCH x 75 PITCHES	1	Z09-AW-75
22	CHAIN STRIPPER	1	TD610-185
23	M10 HEX NUT	2	Z18-10
24	10mm DIA FLAT WASHER	6	Z10-02-10
25	M10 HEX HD SET x 30mm LONG	3	Z26-062S
26	KEY 12mm x 10mm x 55mm LONG	1	WD610-198
27	M10 CUP SQ. SCREW x 30mm LONG	1	Z13-112
28	M10 HEX HD BOLT x 80mm LONG	1	Z26-00691B
29	CHAIN GUARD (SMALL)	1	WD90-CGS
30	CHAIN GUARD (LARGE)	1	WD90-044
31	M10 HEX HD SET x 25mm LONG (TUFLOCK)	3	Z26-061S
32	SPROCKET/BACKET PIVOT SHAFT	1	WD610-71
33	1" UNC LOCKNUT	1	Z23-251
34	1" DIA H/D FLAT WASHER	2	Z10-02-25
35	LOCKING PLATE	2	WD623-060
36	SPIRAL PIN	2	Z03-23--062
37	SPROCKET	1	Z06-D65-1316S
38	M6 GRUB SCREW	2	Z28-006
39	CHAIN TENSIONER BRACKET	1	WD610-CTB1
40	CHAIN TENSIONER BLOCK ASSY INNER	1	WD610-TBI1
41	CHAIN TENSIONER BLOCK ASSY OUTER	1	WD610-TB01
42	SPRING 14.5mm O.D. x 1.6mm WIRE x 60mm LONG	1	Z07-48
43	M10 HEX HD SET x 40mm LONG	1	Z26-064S
44	OILITE BUSH	2	Z06-106
45	M10.9 x 30mm SETS	2	Z26-062SB
46	MAGNET	2	D6043
47	M6 CSK HD SET x 35mm LONG	2	Z13-132
48	6mm DIA FLAT WASHER	2	Z11-02-06
49	M6 LOCKNUT	2	Z23-06

TANCO AUTOWRAP 1080 MODELS MAIN ASSEMBLY

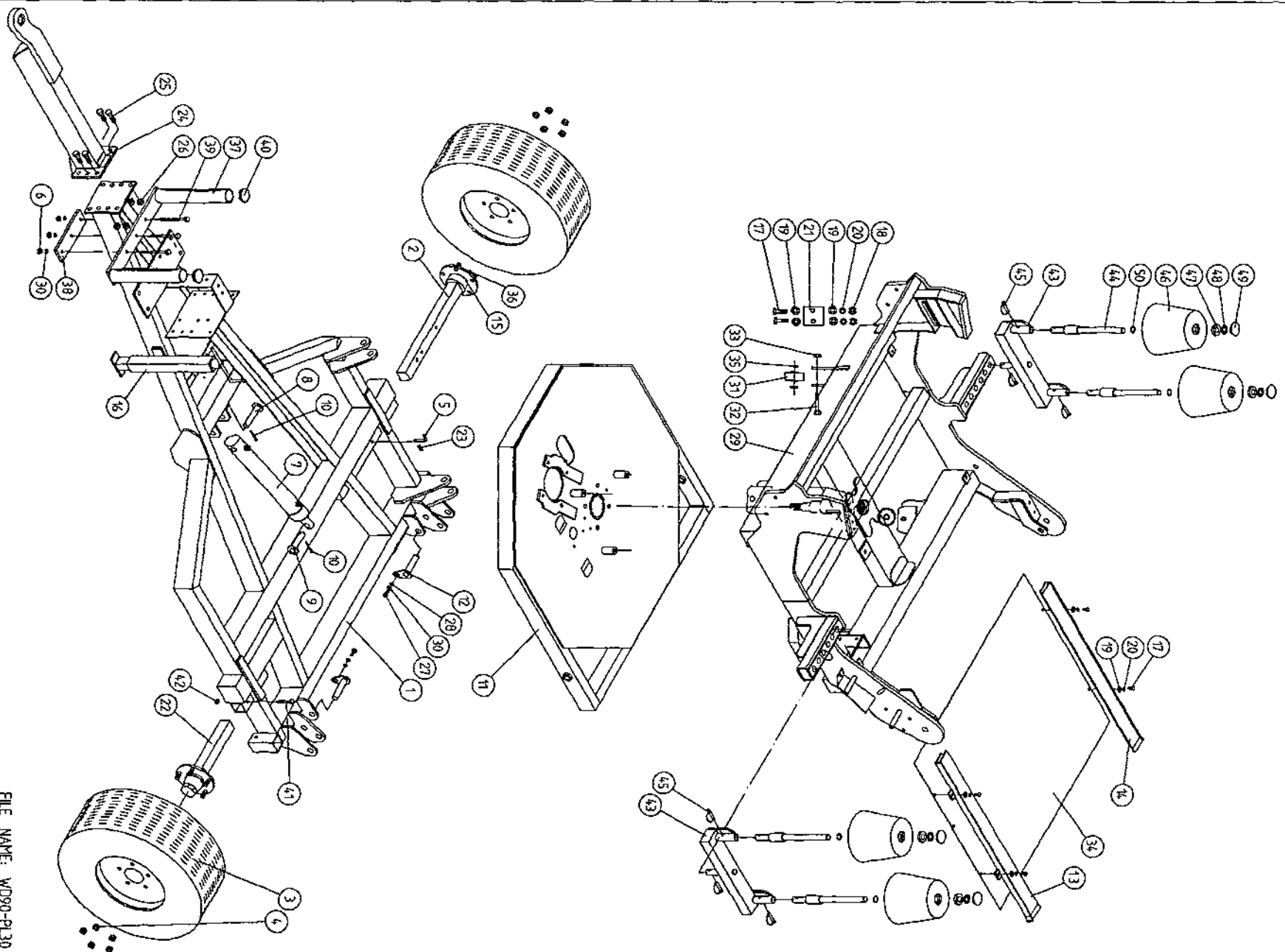

FILE NAME: WD90-PL30

**TANCO AUTOWRAP 1080 MODELS
PARTS LIST**

ITEM NO.	DESCRIPTION	QTY	PART NO.
1	CHASIS ASSY	1	WD67-CHA
2	STUB AXLE (LONG)	1	Z04-0336
3	WHEELS	2	Z04-04-1070
4	WHEELS NUTS	10	M22AWNA
5	BISSEL PIN	1	WD60-861
6	M10 HEX NUT	3	Z18-10
7	HYD RAM	1	Z01-01AR687
8	RAM BOTTOM PIVOT PIN	1	Z03-02-330
9	RAM TOP PIVOT PIN	1	Z03-03-50
10	2' x 1/4" SPLIT PIN	2	Z03-21-29
11	TIPPING FRAME ASSY	1	WD67-TF
12	TIPPING FRAME PIVOT PIN C/W GREASE NIPPLE	2	Z03-01-9055
13	BELT GUIDE ASSEMBLY	1	WD610-BG1
14	BELT GUIDE ASSEMBLY	1	WD610-BG2
15	INNER BEARING	2	M22AB-209
16	SCREW JACK ASSEMBLY (WELD ON)	1	WD60-JA
17	M8 HEX HD SETS x 20mm LONG	4	Z26-039S
18	M8 HEX NUTS	14	Z18-08
19	8m DIA FLAT WASHERS (MUD FLAP)	8	Z11-02-081
20	8mm DIA SPRING WASHERS	12	Z12-02-08
21	SCRAPER	2	WD60-711
22	STUB AXLE SHORT	1	Z04-032
23	4 mm "R" CLIP	1	Z36-02
24	RING HITCH ASSY (LONG)	1	WD65-HIT
25	M16 HEX HD SET x 25mm LONG	4	Z26-124S
26	M16 LOCKNUTS	4	Z23-16
27	M10 HEX HD SET x 25mm LONG	2	Z26-060SY
28	10mm DIA MACHINED FLAT WASHER	2	Z11-02-1 0
29	TURN TABLE ASSY	1	WD610-TA2
30	10mm DIA SPRING WASHER	5	Z12-02-10
31	SUPPORT WHEELS	4	Z06-466
32	AXLE ASSY C/W GREASE NIPPLE	4	Z03-22-AW/AX
33	M20 LOCKNUTS	4	Z23-20
34	TURN TABLE COVER PLATE	1	WD60-093
35	SPACER	8	WD60-198
36	OUTER BEARING	2	M22AB-206
37	FILM TRANSPORT BRACKET	1	WD60-FTB1
38	CLAMPING PLATE	1	WD60-933
39	M10 HEX HD BOLT x 140mm LONG	3	Z26-0726B
40	PLASTIC CAP	2	Z32-08
41	M10 HEX HD BOLT x 80mm LONG	1	Z26-0691B
42	M10 LOCK NUT	1	Z23-10
43	END ROLLER MOUNTING BRACKET	2	WD610-RMB
44	END ROLLER SHAFT ASSY	4	WD610-RSA
45	10mm DIA "D" LINCH PIN	6	Z38-03
46	SIDE ROLLER	4	Z06-AWR
47	BEARING 25mm I.D.	4	Z06-AWRB-93
48	THRUST WASHER	4	WD60-292
49	PLASTIC CAP	4	Z06-AWRC
50	CIRCLIP	4	Z28-525

TANCO AUTOWRAP TURNTABLE CHAIN DRIVE ASSEMBLY

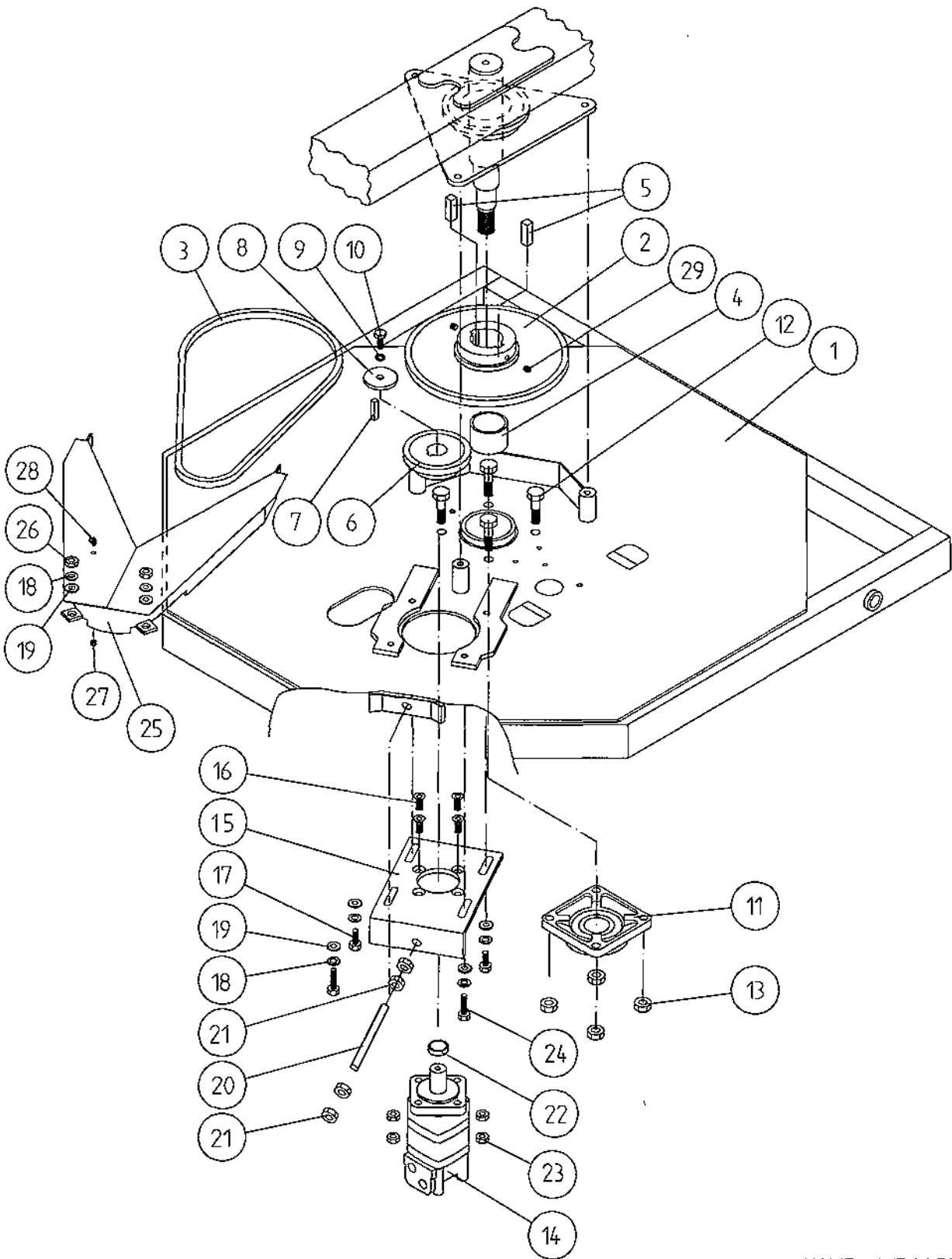

FILE NAME: WD66 PL9

**TANCO AUTOWRAP
TURNABLE CHAIN DRIVE ASSEMBLY**

PARTS LIST

ITEM NO	DESCRIPTION	QTY	PAPT NO
1	TIPPING FRAME ASSY	1	WD67-TF
2	38 TOOTH x 1" PITCH SPROCKET	1	Z06-D64-38
3	CHAIN 1" PITCH x 54 PITCHES	1	Z09-AW6
4	SPINDLE SPACER	1	WD64-040
5	KEY 5/8" SQ x 50mm LONG	2	WD64-052
6	15 TOOTH x 1" PITCH SPROCKET	1	Z06-I60-046
7	KEY 5/16" SQ x 45mm LONG	1	WD64-053
8	LOCKING COLLAR	1	WD623-071
9	10mm DIA SPRING WASHER	1	Z12-02-10
10	3/8" UNC HEX HD SET x 1" LONG	1	Z27-023S
11	2" DIA FLANGE BEARING C/W CAM LOCK COLLAR	1	Z06-49EC
12	5/8" UNF HEX HD SET x 2" LONG	4	Z31B-064
13	5/8" UNF LOCKNUT	4	Z20-10
14	HYDRAULIC MOTOR	1	Z01-02-RF200
15	HYDRAULIC MOTOR MOUNTING PLATE	1	WD64-001
16	M12 x 50mm ALLEN HD O/S SCREW	4	Z13-5-12X50
17	M12 HEX HD SET x 30mm LONG	4	Z26-082S
18	12mm DIA SPRING WASHER	4	Z12-02-12
19	12mm DIA FLAT WASHER	4	Z10-02-12
20	M16 THREADED BAR x 150mm LONG	1	WD64-038
21	M16 HEX NUT	4	Z18-16
22	SPACER	1	Wi60-093
23	M12 LOCKNUTS	4	Z23-12
24	M12 HEX HD SET x 50mm LONG	2	Z26-086S
25	DRIVE CHAIN GUARD	2	WD66-DCG
26	M12 HEX NUT	2	Z18-12
27	M6 HEX NUT	1	Z18-06
28	M6 90 DEGREE GREASE NIPPLE	1	Z39-65
29	M12 GRUB SCREW x 16mm LONG	2	Z28-012

TANCO AUTOWRAP 1080 MODELS
BALE BELT ROLLER MOUNTING BRACKETS

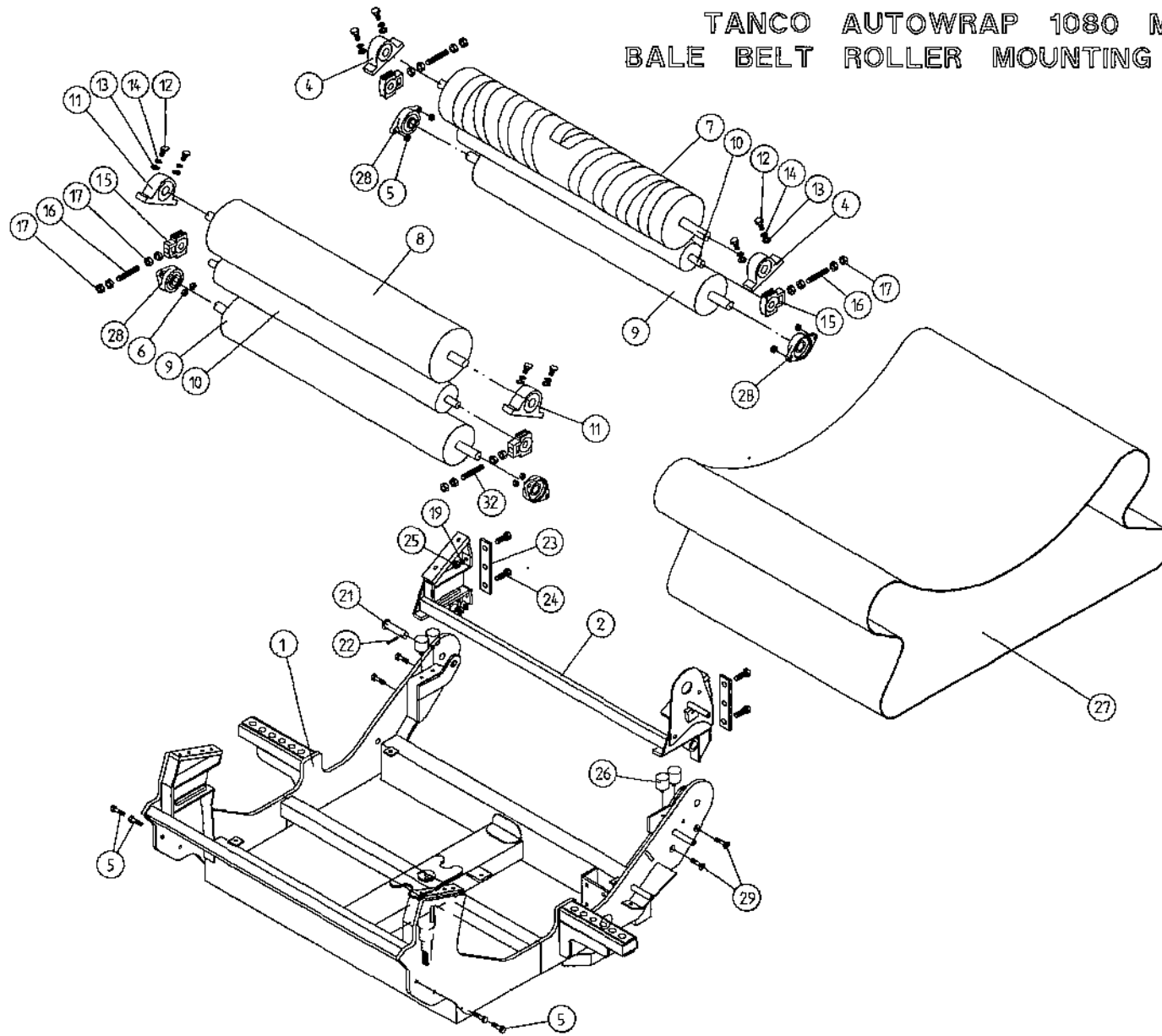

047

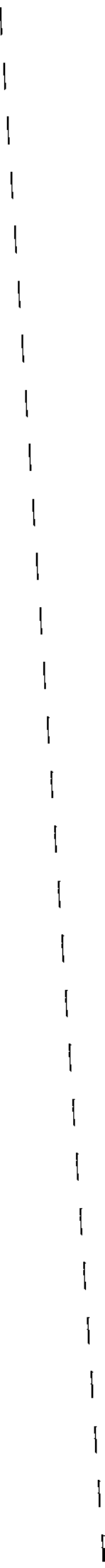

**TANCO AUTO WRAP 1080 MODELS
BALE BELT ROLLER MOUNTING BRACKETS**

PARTS LIST

ITEM NO.	DESCRIPTION	QTY	PART-NO.
1	TURNTABLE ASSY.	1	WD90-TA
2	ROLLER MOUNTING BRACKET (SWIVEL)	1	WD610-RMS1
3	M20 THREADED BAR x 105mm LONG	1	WD610-113
4	40mm DIA PILLOW BLOCK BEARING	2	Z06-48EC-40
5	M12 x 45mm SETS	6	Z26-085S
6	M12 LOCKNUTS	8	Z23-12
7	BIG ROLLER ASSY (DRIVE)	1	WD610-BRD1
8	BIG ROLLER ASSY (IDLER)	1	WD610-BRI
9	ROLLER ASSY (IDLER)	2	WD65-BRI
10	TPACKING ROLLER ASSY (LONG)	2	WD610-TPL
11	1 1/4" PILLOW BLOCK BEARING	2	Z06-485
12	M14 HEX HD SET x 45nun LONG	8	Z26-103S
13	14mm DIA FLAT WASHER	16	Z11-02-14
14	14mm DIA SPRING WASHER	16	Z12-02-14
15	SLIDING BEARING-STI	4	Z06-47ST
16	M20 THREADED BAR x 135mm LONG	3	WD610-77
17	M20 HEX NUTS	16	Z18-20
18	12mm DIA. SPRING WASHER	12	Z12-02-12
19	12mm DIA. FLAT WASHER	8	Z11-02-10
21	SWIVEL BP-ACKET PIVOT PIN J-50	1	Z03-03-50
22	211 x 1/411 SPLIT PIN	1	Z03-21-29
23	RETAINING PLATE	2	WD610-30
24	M12 HEX HD SETS x 40mm	4	Z26-084S
25	M12 HEX NUTS	6	Z18-12
26	BUFFER SOMM DIA x 42mm LONG	4	Z40-235
27	BALE BELT 1130nun WIDE x 4470mm LONG	1	Z05-02AWV1-93
28	1 1/4" FLANGE BEARING 2 HOLE	4	WD610-CSM
29	M14 HEX NUTS	8	Z18-14

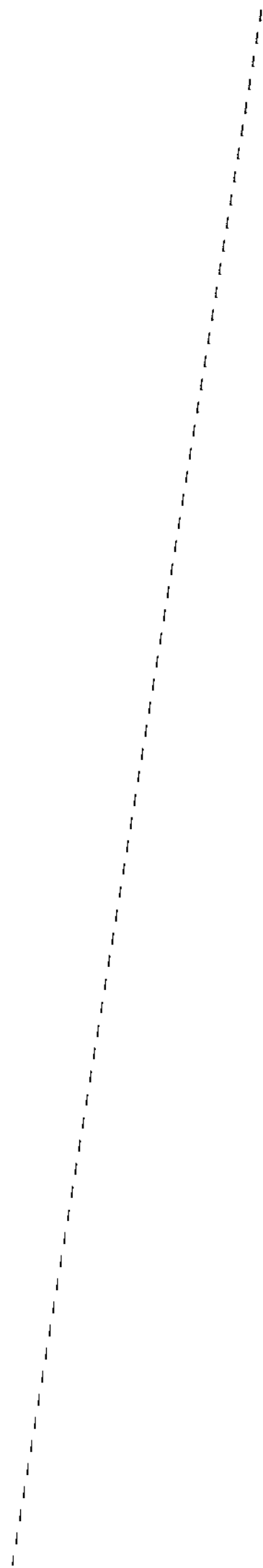

TANCO AUTOWRAP 180A/1080ATP MODELS
FILM DISPENSER SYSTEM

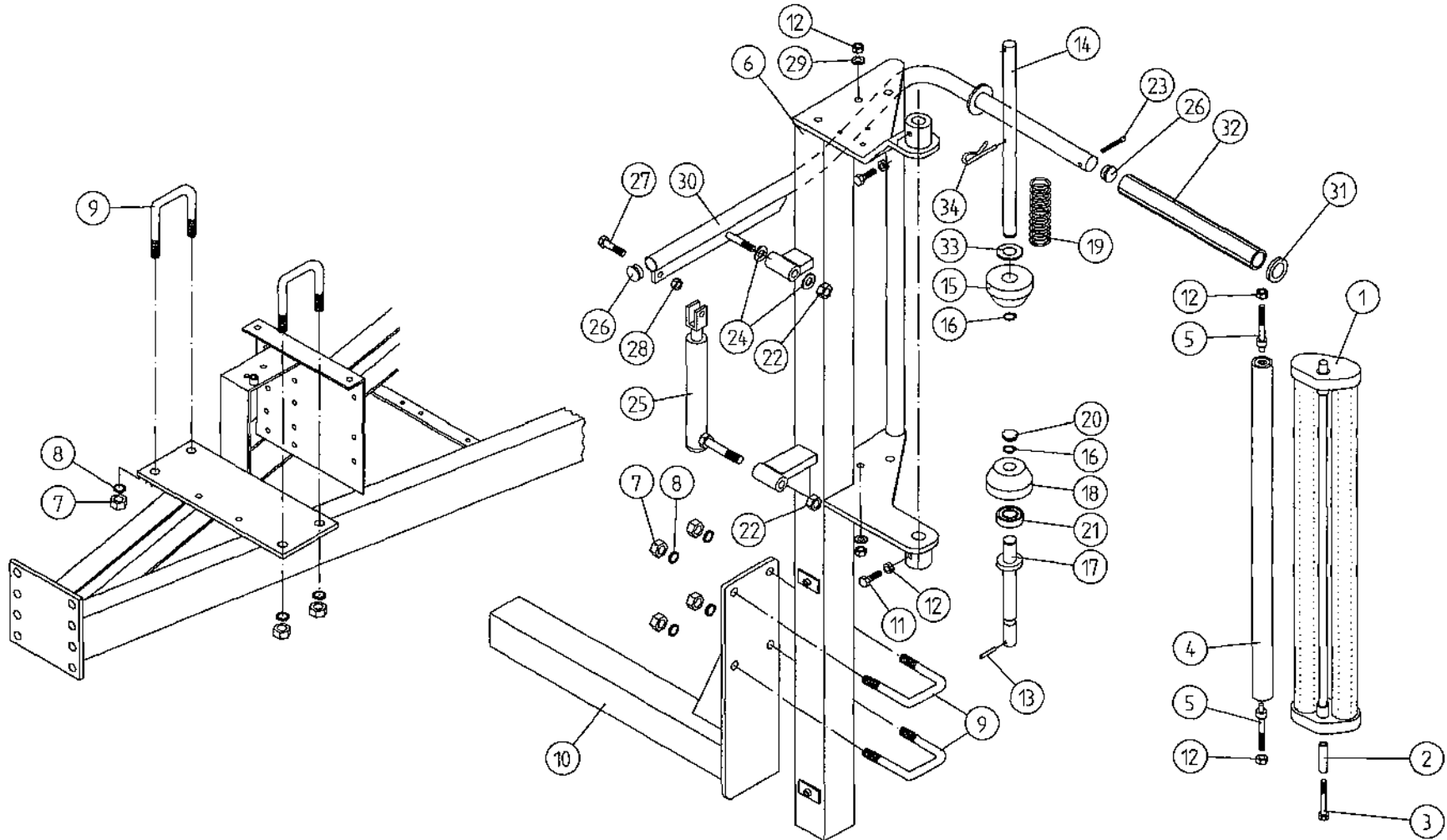

4/2

**TANCO AUTOWRAP 1080A/1080ATP MODELS
FILM DISPENSING SYSTEM
PARTS LIST**

ITEM NO	DESCRIPTION	QTY	PART NO
1	FILM DISPENSER UNIT MK9 (70% STRETCH)	1	D616
2	SLEEVE	1	D52012-95
3	M12 x 80 HEX BOLT	1	Z26-0901B
4	SLAVE ROLLER LONG	1	Z06-SR95-L
5	SLAVE ROLLER PIVOT	2	WD64-SRP
6	DISPENSER MAST	1	WD90-DM
7	M16 HEX NUT	8	Z18-16
8	16mm DIA SPRING WASHER	8	Z12-02-16
9	80mm x M16 'U' BOLTS	4	Z35-52
10	DISPENSER MAST MOUNTING BRACKET	1	WD67-DMM
11	M12 x 30 HEX SET	2	Z26-084S
12	M12 HEX NUT	4	Z18-12
13	5mm DIA x 45 ROLL PIN	2	Z03-21-15
14	FILM SPOOL UPPER	1	WD90-11
15	TOP CONE	1	WD90-012
16	CIRCLIP	2	Z28-525
17	FILM SPOOL LOWER	1	WD67-FSU
18	BOTTOM CONE	1	WD90-013
19	SPRING	1	Z07-07
20	PLASTIC CAP 1 1/4" DIA	1	Z39-60
21	BEARING	1	Z06-AWRB
22	M16 LOCKNUT	2	Z23-16
23	1/4" x 2" SPLIT PIN	2	Z01-23-29
24	16mm DIA FLAT WASHER	2	Z10-02-16
25	HYDRAULIC RAM (PULL DOWN)	1	Z01-01-AW25
26	1" G.B. PLASTIC CAP	2	Z32-14
27	M12 X 50 HEX SET	1	Z26-086S
28	M12 LOCKNUT	1	Z23-12
29	12mm DIA SPRING WASHER	1	Z12-02-12
30	FILM PULL DOWN ARM ASSEMBLY	1	WD90-FPDA
31	RETAINING WASHER	1	WD60-859
32	ROLLER	1	WD60-866
33	1" DIA FLAT WASHER	1	Z10-02-30
34	6mm "R" CLIP	1	Z36-03

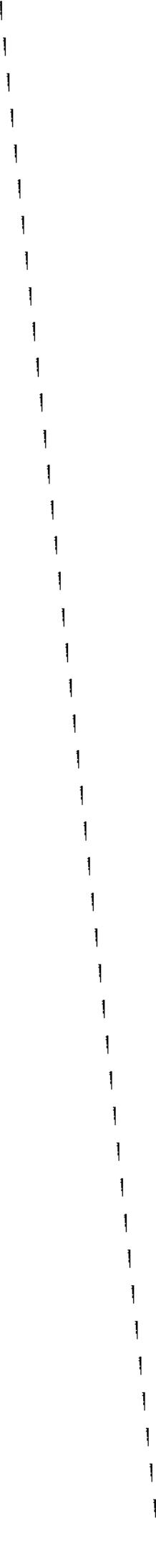

WD80-PL21

**TANCO AUTOWRAP 1080 ATP MODEL
VALVE JUNCTION BOX FILTER & DIVERTER VALVE MOUNTING
BRACKET ASSEMBLY**

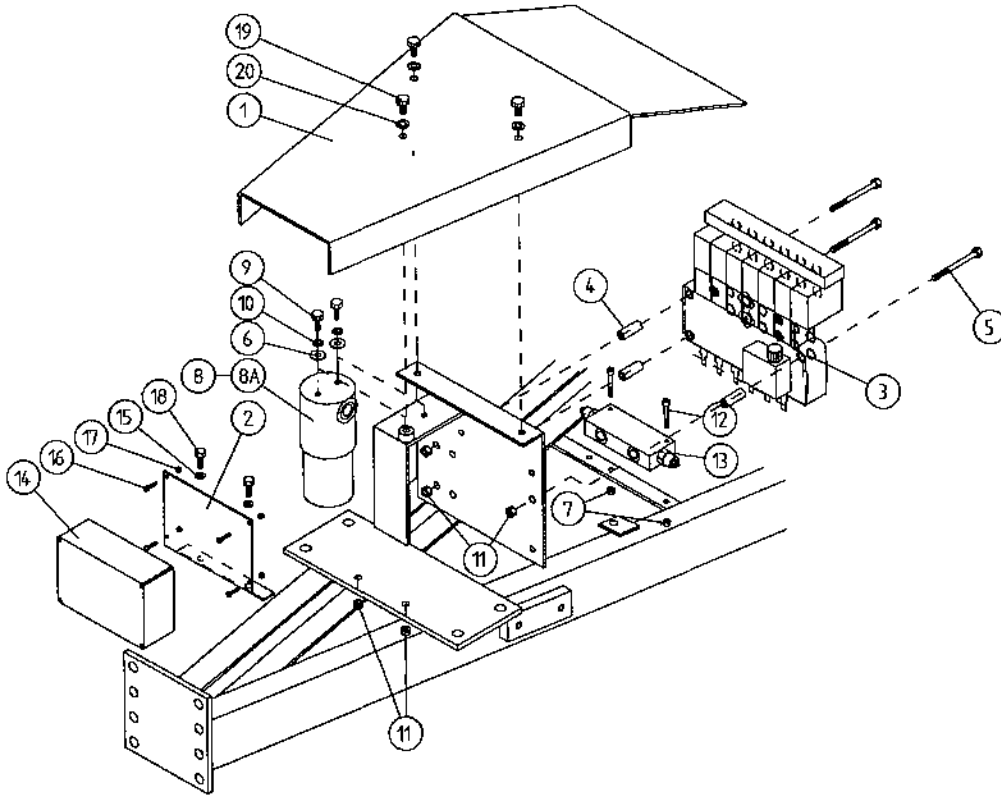

ITEM NO:	DESCRIPTION:	QTY:	PART NO:
1	VALVE COVER PLATE ASSY	1	WD75-VCP
2	JUNCTION BOX MOUNTING PLATE	1	WD66-041
3	6 BANK SOLENOID VALVE	1	Z01-03-A1060TP
4	SPACER FOR VALVE	3	WD67-100
5	M8 x 100 HEX SET	3	Z26-057S
6	8mm DIA MUD FLAP WASHER	2	Z11-02-081
7	M6 LOCKNUT (NYLOCK)	2	Z32-06
8	OIL FILTER	1	Z01-24-08
8A	OIL FILTER ELEMENT	1	Z01-24-08E
9	M8 HEX HD SET x 25MM	2	Z26-040S
10	8mm DIA SPRING WASHER	8	Z12-02-08
11	M8 LOCKNUTS	5	Z23-08
12	M6 ALLEN HD SOCKET SCREW x 45mm	2	Z13-020-50
13	OVER-CENTRE VALVE	1	Z01-03-10-A8
14	JUNCTION BOX	1	ZDG-0550A
15	8mm DIA FLAT WASHER	4	Z10-02-08
16	M4 ALLEN HD SOCKET SCREW x 16mm	4	Z26-006
17	M4 LOCKNUT	4	Z23-04
18	M8 x 20 HEX SET	2	Z26-039S
19	M10 x 20 HEX SET	5	Z26-060S
20	10mm DIA FLAT WASHER	3	Z12-02-10

TANCO AUTOWRAP 1060 ATP MODEL
"TWIN-PAK" LIFT ARM ASSEMBLY

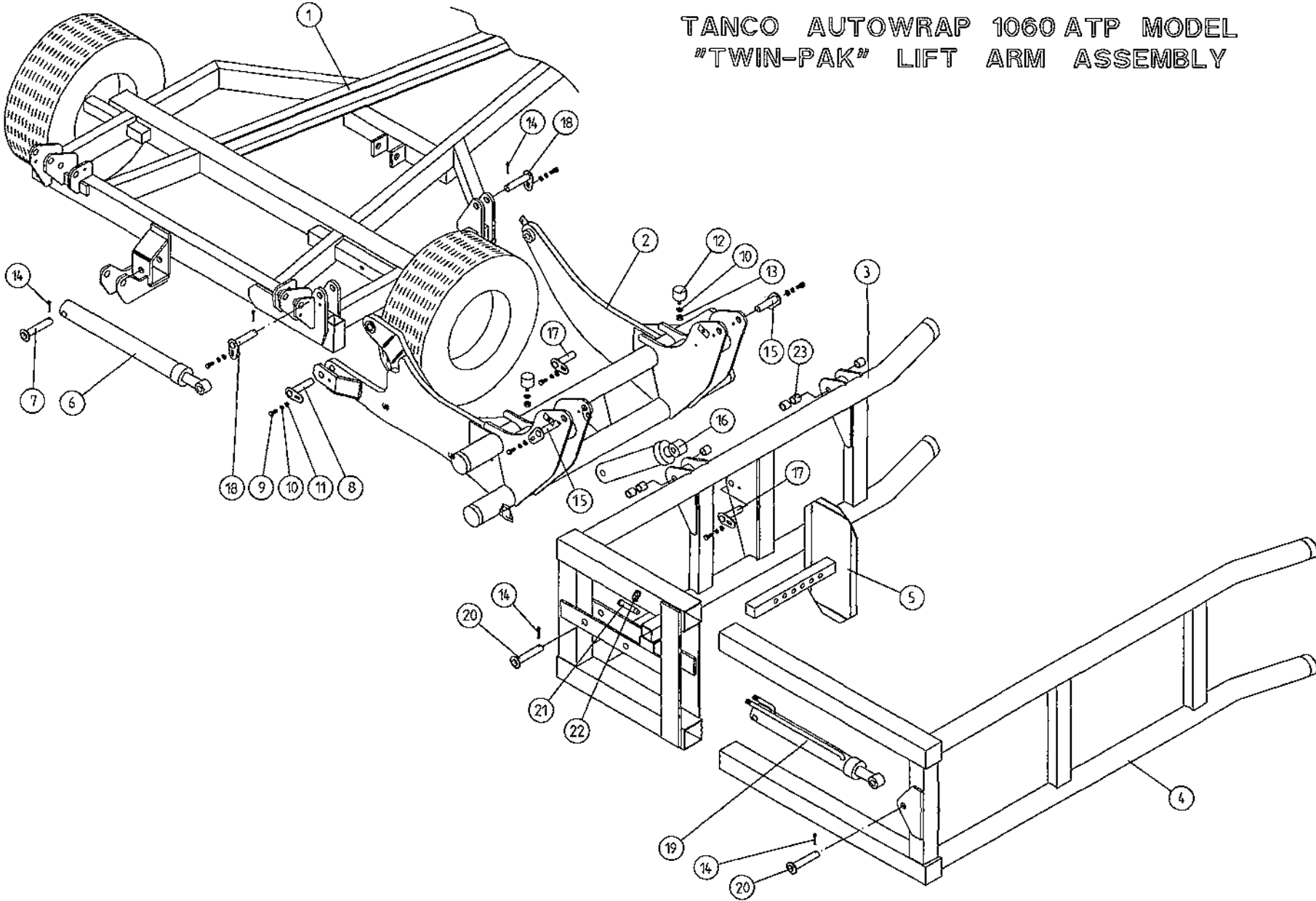

54

**TANCO AUTOWRAP 1080 ATP MODEL
"TWIN-PAC" LIFT ARM ASSY**

PARTS LIST

ITEM NO.	DESCRIPTION	QTY	PART-NO
1	CHASSIS ASSY	1	WD67-CHA
2	MAIN ARM ASSY	1	WD610-TMA
3	INNER FRAME ASSY	1	WD610-TIA
4	OUTER FRAME ASSY	1	WD610-TOA
5	BALE STOP ASSY	1	WD610-LAS1
6	HYDRAULIC RAM (MAIN ARM)	1	Z01-01-AW
7	RAM BOTTOM PIVOT PIN	1	Z03-02-330
8	RAM TOP PIVOT PIN	1	Z03-01-797
9	M10 HEX HD SET x 20mm LONG	7	Z26-060ST
10	10mm DIA SPRING WASHER	9	Z12-02-10
11	10mm DIA FLAT WASHER	7	Z11-02-10
12	BUFFER 50mm DIA x 40mm LONG	2	Z40-20
13	M10 HEX NUT	2	Z18-10
14	1/4" DIA SPLIT PIN x 2" LONG	5	Z03-21-29
15	INNER FRAME PIVOT PIN	2	Z03-02-192
16	HYDRAULIC RAM (INNER FRAME)	1	Z01-01-DA980
17	RAM TOP/BOTTOM PIVOT PIN	2	Z03-01-796
18	MAIN PIVOT PIN C/W GREASE NIPPLE	2	Z03-01-905
19	HYDRAULIC RAM (OUTER FRAME)	1	Z01-01-140S
20	RAM TOP/BOTTOM PIVOT PIN	2	Z03-02-54
21	BALE STOP RETAINING PIN	1	Z03-04-73
22	7/16" DIA LINCH PIN	1	Z03-22-06
23	TENSION BUSH 1 1/4" x 1" x 30mm LONG	6	Z03-20-014

TANCO AUTOWAP HYDRAULIC BALE RAMP

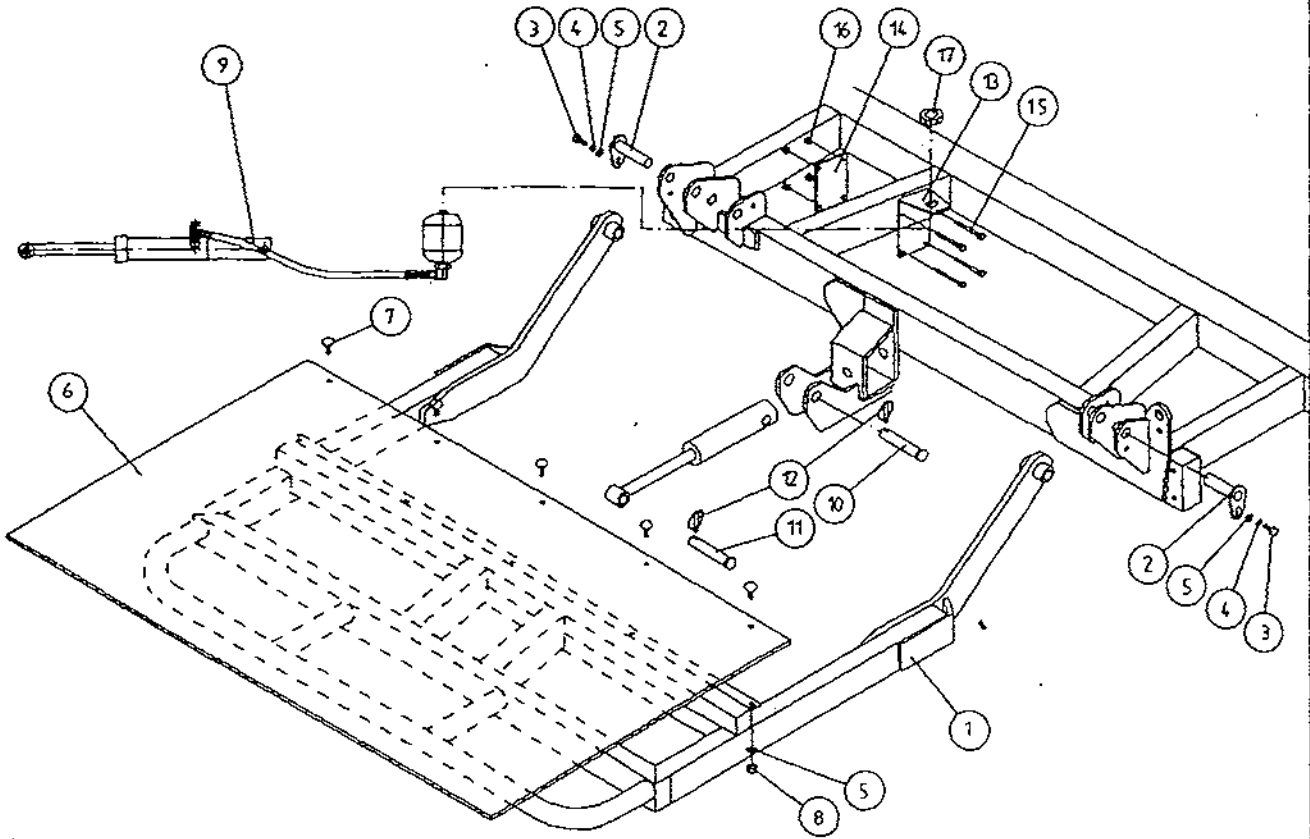

INSTRUCTIONS FOR RECHARGING AND REDUCING PRESSURE IN HYDRAULIC BALE RAMP CYLINDER

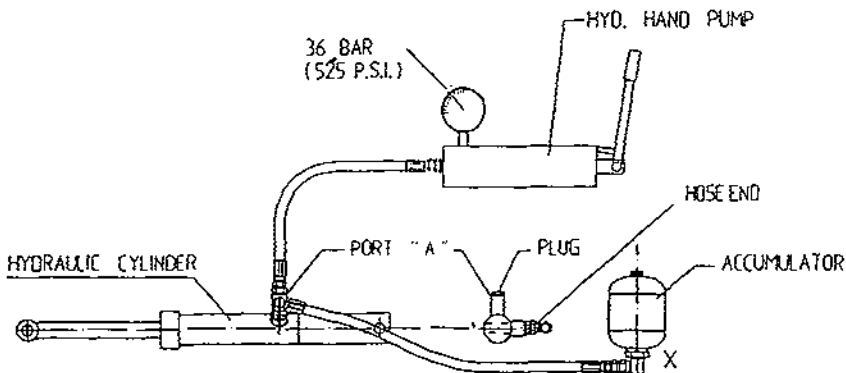

TO RECHARGE CYLINDER:

1. REMOVE PLUG FROM PORT "A".
2. CONNECT HOSE FROM HYD. HAND PUMP TO PORT "A".
3. CHARGE CYLINDER TO A PRESSURE OF 36 BAR (525 P.S.I.)
4. BLEED AIR FROM SYSTEM BY SLACKENING HOSE CONNECTION AT BASE OF ACCUMULATOR MARKED X. RETIGHTEN CONNECTION.
5. REMOVE PUMP HOSE FROM PORT "A" AND REFIT PLUG.

TO REDUCE PRESSURE IN CYLINDER:

1. SLACKEN CONNECTION ON HOSE END JUST ENOUGH TO ALLOW OIL TO BLEED OUT SLOWLY.
2. RETIGHTEN CONNECTION AND CHECK OPERATION OF BALE RAMP AS DETAILED IN FIG 1.
3. REPEAT PROCEDURE UNTIL OPERATION OF RAMP IS CORRECT.

FILE NAME WD66-PLZE

WD64-PL25

TANCO AUTOWRAP 1998 MODEL

HYDRAULIC BALE RAMP

ITEM	DESCRIPTION:	QTY:	PART NO:
1	HYDRAULIC BALE RAMP ASSY	1	WD65-HBRF
2	RAMP MAIN PIVOT PIN C/W GREASE NIPPLE	2	Z03-01-905
3	M10 HEX HD SET X 20mm LONG TUFLOCK	2	Z26-060ST
4	10MM DIA MACHINED FLAT WASHER	2	Z11-02-10
5	10MM DIA SPRING WASHER	12	Z12-02-10
6	BALE MAT	1	Z05-02-BRH
7	M10 X 30MM LONG CUP HD.SQ BOLTS	5	Z13-112
8	M10 HEX NUTS	5	Z18-10
9	HYDRAULIC RAM C/W ACCUMULATOR	1	Z01-01-AWD
10	SPAREX PIN	1	Z03-04-74
11	SPAREX PIN	1	Z03-04-73
12	7/16 DIA LINCH PIN	2	Z03-22-06
13	ACCUMULATOR MOUNTING PLATE	1	WD65-AMP
14	CLAMPING PLATE	1	WD65-231
15	M8 HEX HD BOLT X 80MM LONG	4	Z26-050B
16	M8 LOCKNUT	4	Z23-08
17	M28 X 1.5 PITCH HEX NUT	1	Z18-28

FAULT FINDING

PROBLEMS.

REMEDY.

1. Drive Roller and Bale belt not driving
Check and replace shear Pins in sprocket on drive roller.
2. Film Breaking
Wash off dispenser and slave rollers. Change roll of film. Use recommended films only.
3. Film not wrapping evenly on bale.
Adjust film mast so centre of film roll is aligned with centre of bale .
4. Film Tearing on Ramp.
Check for sharp edges and remove.
5. Bale Skidding on Ramp.
Fit Hessian Bag or piece of carpet to Ramp.
6. Film Dispenser not Pre-Stretching Film.
Check that both Rollers turn when one is turned by hand. If not, fit new gears or replace unit.
7. Tyres coming off 4" platform Support Wheels.
Replace Wheels - Reduce speed below 30 r.p.m. - Do not grease path of wheels on platform. Check that bale does not get trapped between arms and turntable when being loaded.

If this happens lower arm and start again.
8. Hydraulic Bale Ramp not returning to raised position after tipping off bale.
See instructions for recharging hydraulic cylinder.
9. Bale Belt Tracking Adjustment
 - (i) Ensure vertical rollers (plastic) are in tight on the bale. Remember that the bale will reduce in size during wrapping and, on the round bales in particular, the corners will become rounded so that the bale will tend to move sideways due to centrifugal forces. Now, if the plastic rollers are too far apart, the bale will move against one of the plastic rollers causing the belt to move in the opposite direction. Always adjust the vertical plastic rollers so that they keep the bale central on the belt.
 - (ii) Adjust bale stop on lift arm so that bale is loaded centrally onto platform.
 - (iii) Check that bale belt is fitted so arrow points in direction of travel.
 - (iv) Check that both 8" rollers underneath the bale belt are parallel to each other. Remember the golden rule - a belt will always move up a slope: So, if the belt continually moves to our side, adjust idler roller to a narrower setting on the opposite side to which the belt travels.
 - (v) Check that gripface strips are securely fixed to the roller and have not moved out of alignment.
 - (vi) Check that is the same measurement each side by running a string around the belt and measuring it. If one side is longer than the other replace the belt.

TANCO AUTOWRAP
HYDRAULIC CUT AND START
MAIN ASSEMBLY

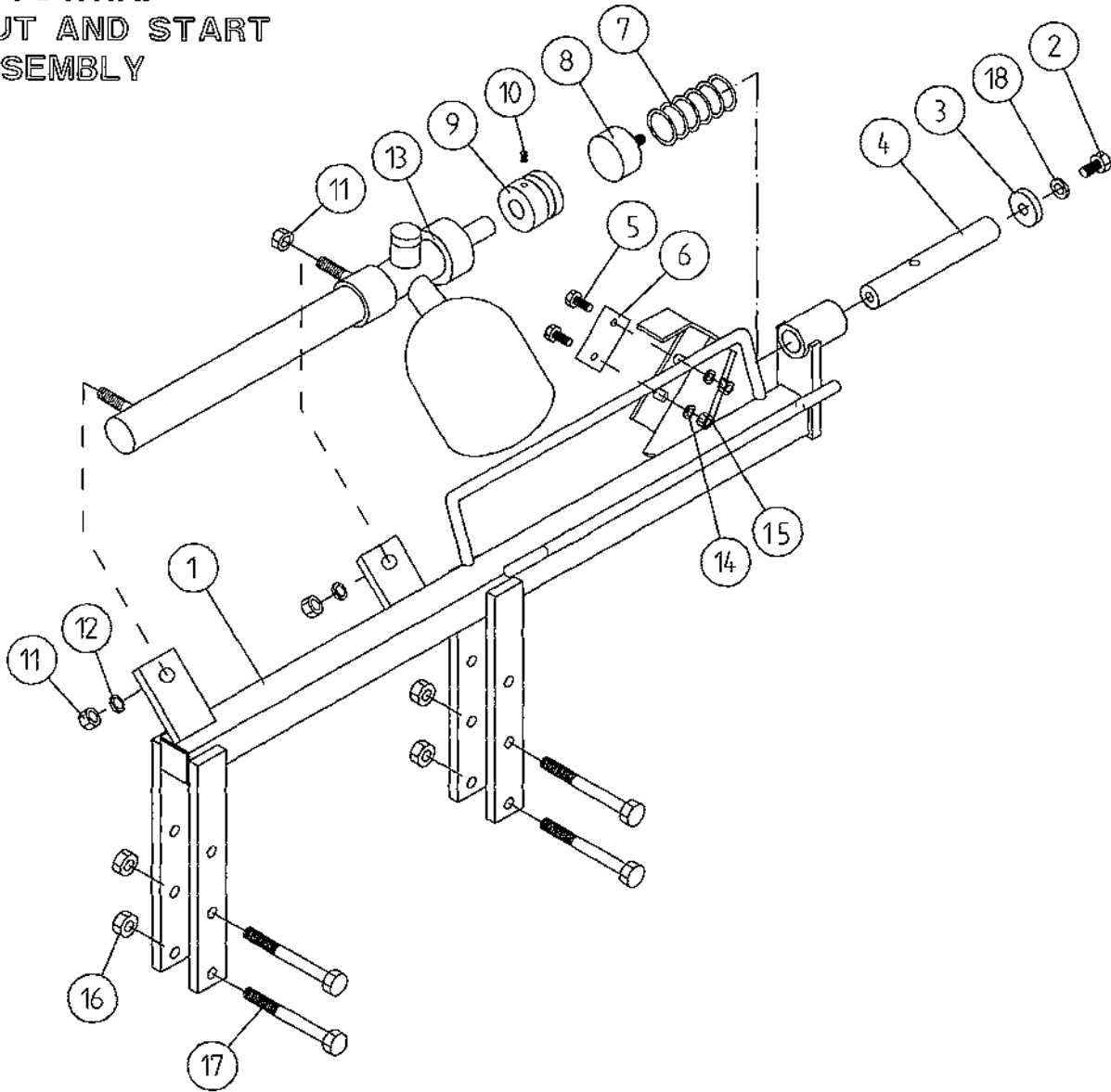

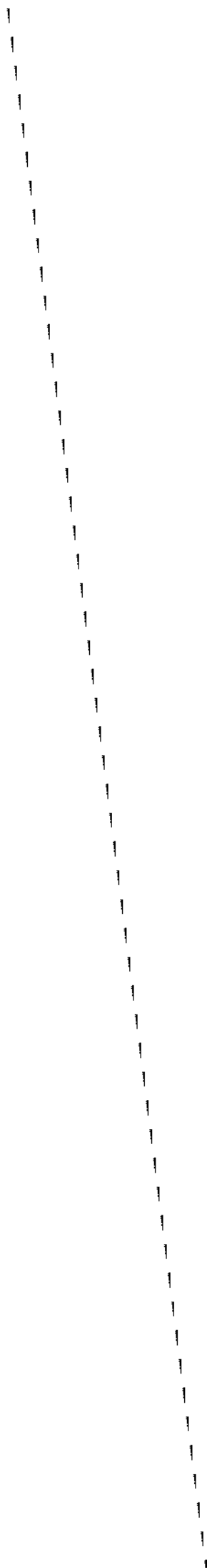

**TANCO AUTOWRAP
HYDRAULIC CUT AND START UNIT
PARTS LIST**

ITEM NO.	DESCRIPTION	QTY	PART NO.
1	HYDRAULIC CUT AND START MAIN FRAME	1	WD605H-MF
2	M10 x 25 HEX SET	1	Z26-061S
3	LOCKING COLLAR	1	Wi60-090
4	GRIPPER ROD	1	WD605H-13
5	H6 X 25 HEX SET	1	Z26-0405
6	BLADE	1	605-104
7	SPRING	1	Z07-49
8	GRIPPER PAD (RUBBER)	1	Z40-28
9	GRIPPER PAD	1	WD605H-15
10	M8 X 10 GRUB SCREW	1	Z28-008
11	M 14 HEX NUT	3	Z18-14
12	14MM SPRING WASHER	2	Z12-02-14
13	CUT & START HYDRAULIC RAM ACCUMULATOR	1	Z01-01-AWH9
14	8MM FLAT WASHER	2	Zi1-02-08
15	M8 LOCK NUT	2	Z23-08
16	M 10 LOCK NUT	4	Z23-010
17	M10 X 75 HEX BOLT	4	Z26-069B
18	10mm DIA SPRING WASHER	1	Z12-02-10

TANCO AUTOWRAP - HYDRAULIC CUT AND START

INSTRUCTIE VOOR HET OPLADEN HYDRAULISCHE CILINDER

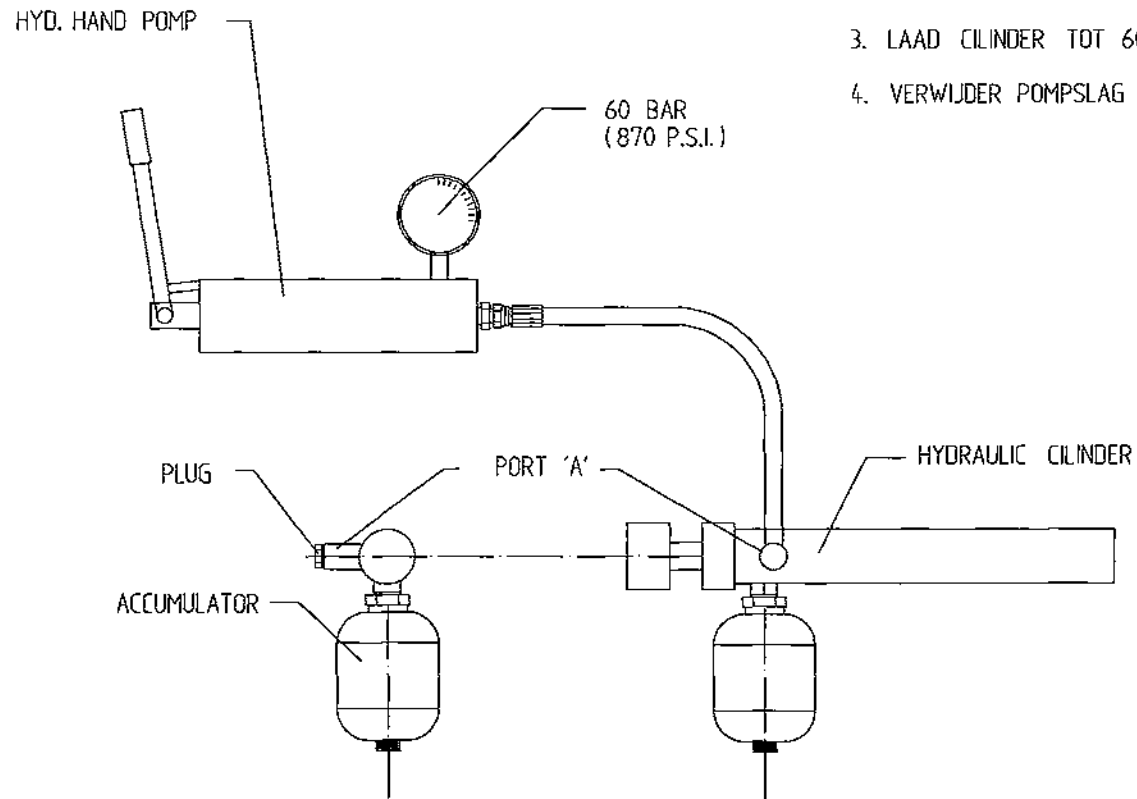

1. VERWIJDER PLUG UITM PORT "A".
2. VERBIND SLANG VAN HYD. HAND POMP MET PORT "A".
3. LAAD CILINDER TOT 60 BAR (870 P.S.I.)
4. VERWIJDER POMPSLAG EN STOP DE PLUG WEER IN "A".

TANCO AUTOWRAP

TURNTABLE LOCKING ARRANGEMENT

PARTS LIST

ITEM	DESCRIPTION	QTY	PART NO
1	UNDERSIDE OF TIPPING FRAME	1	WD64-TF
2	TURNTABLE CENTRE SHAFT	1	WD64-002
3	SPINDLE SPACER	1	WD67-SS
4	1 1/4" UNC HEX NUT	1	Z18-300
5	M8 GRUB SCREW X 6MM LONG	1	Z28-007

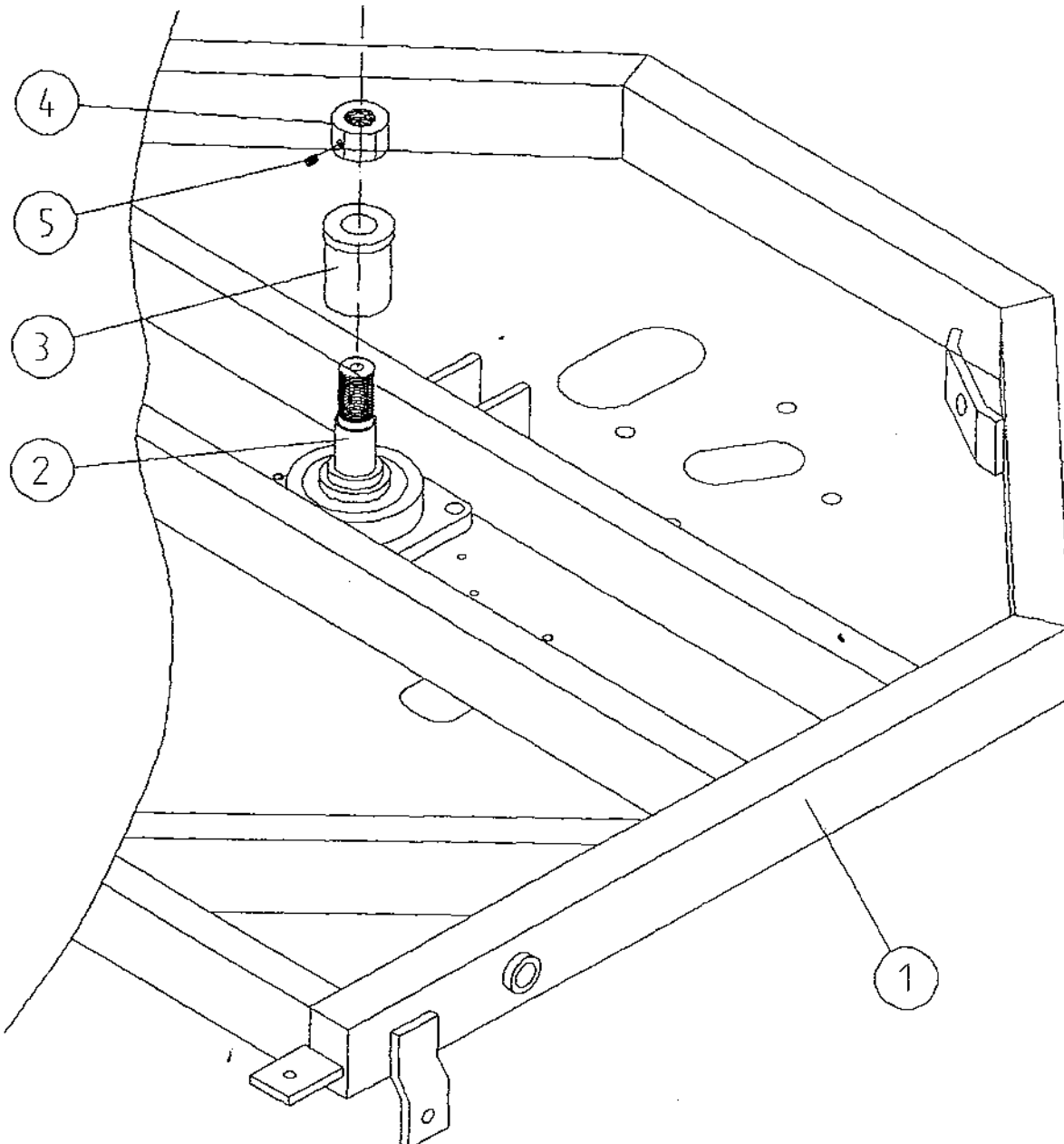

TANCO AUTOWRAP CUT AND START SENSOR AND MAGNET MOUNTING BRACKETS

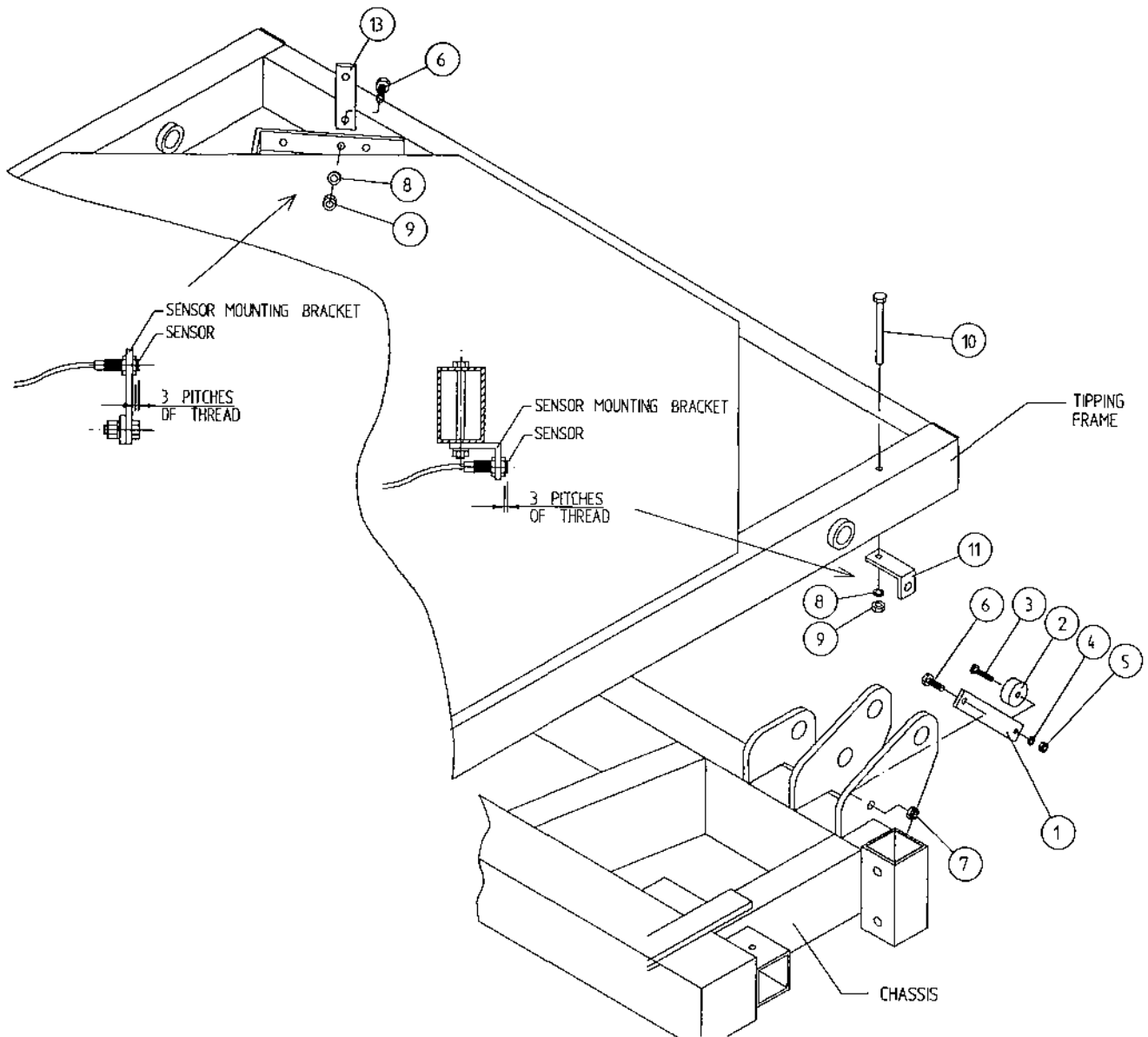

PARTS LIST

ITEM NO	DESCRIPTION	QTY	PART NO.
1	MAGNET MOUNTING BRACKET	1	WD605-165
2	MAGNET	1	D6034
3	M6 HEX HD. SET x 30mm LONG	1	Z26-022S
4	6mm DIA FLAT WASHER	1	Z12-02-06
5	M6 LOCKNUT	1	Z23-06
6	M8 HEX HD. SET x 25mm LONG	2	Z26-040S
7	M8 LOCKNUT (NYLOCK)	1	Z23-08
8	8mm DIA SPRING WASHER	2	Z12-02-08
9	M8 HEX NUT	2	Z18-08
10	M8 HEX HD. SET x 100mm LONG	1	Z26-057S
11	SENSOR MOUNTING BRACKET	1	WD605-58
12	SENSOR MOUNTING FLAT	1	WD605-164

**TANCO AUTOWRAP TRAILED MODELS
LIGHTING KIT**

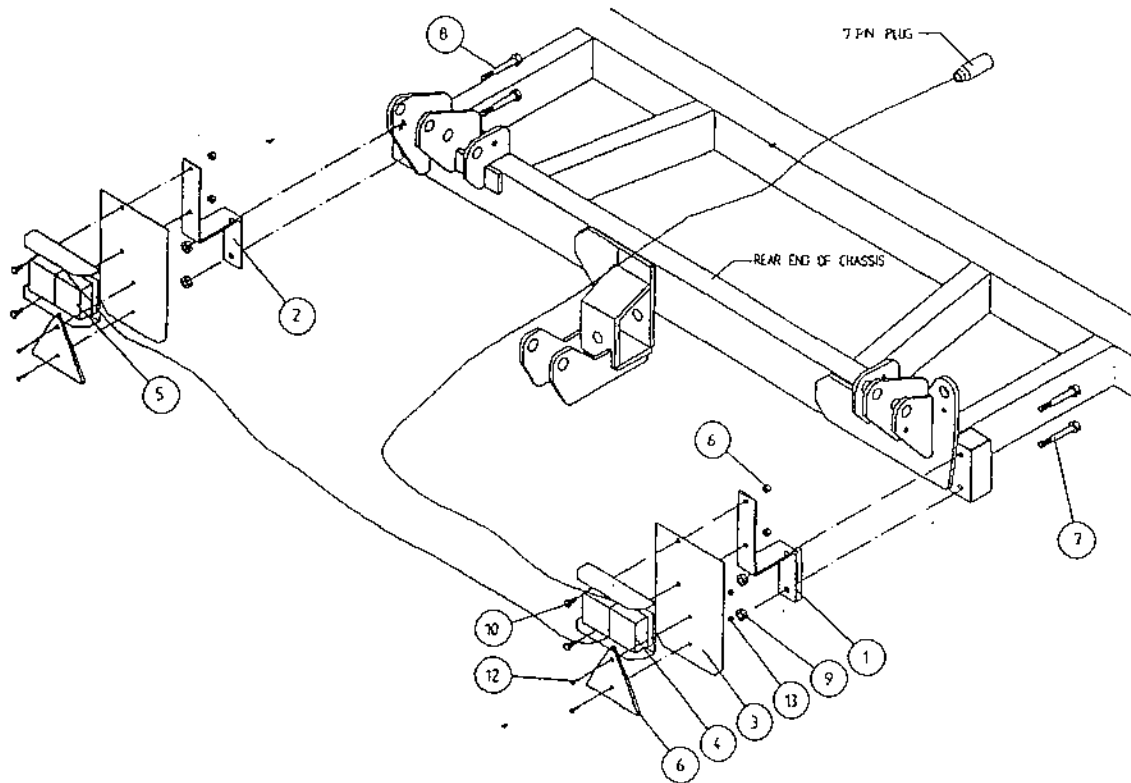

ITEM NO	DESCRIPTION	QTY	PART-NO.
1.	LIGHT MOUNTING BRACKET RHS	1	WD60-LMB
2.	LIGHT MOUNTING BRACKET LHS	1	WD60-899
3.	LIGHT MOUNTING PLATE	2	WD60-898
4.	LIGHT CLUSTER RHS	1	Z05-30R
5.	LIGHT CLUSTER LHS	1	Z05-30L
6.	TRIANGULAR REFLECTOR	2	Z04-62
7.	M12 HEX HD BOLT X 100 LONG	2	Z26-092B
8.	M12 HEX HD BOLT X 90 LONG	2	Z06-091B
9.	M12 LOCKNUT	4	Z23-12
10.	M8 HEX HD SET X 20 LONG	4	Z26-39S
11.	M8 LOCKNUT	4	Z23-08
12.	M6 CHEESE HEAD SET X 20 LONG	4	Z13-15
13.	M6 LOCKNUT	4	Z23-06

EC DECLARATION OF CONFORMITY

ACCORDING TO DIRECTIVES 89/392/336/EEC AS AMENDED.

Manufacturer: TANCO ENGINEERING CO LTD
BAGENALSTOWN
CO CARLOW
IRELAND

CERTIFIES THAT THE FOLLOWING PRODUCT:

AUTOWRAP

MODEL: 1080-ATP

SERIAL NO.: D2600 - D5000

To which this declaration relates, corresponds to the essential requirements of the Directive 89/392/336/EEC as amended.

To conform to these essential health and safety requirements, the provisions of the following harmonised standards were particularly considered:

EN 292 - 1,2, EN 294, EN 1152, prEN 703, prEN 811, prEN 1553, prEN 982.

DATE: 14/01/99

SIGNATURE:

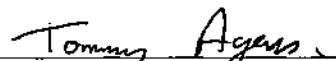

TOMMY AGARS
TECHNICAL MANAGER

